

# Development of Indian High Intensity Proton Accelerator (In Collaboration with Fermilab Project-X)

**Shekhar Mishra**

**Project-X, Fermilab**

**International Collaboration Coordinator**

**Talk Given at BARC/DAE March 22<sup>nd</sup>, 2011**



# My Background



- **Ph.D., Experimental Nuclear Physics, University of South Carolina and Los Alamos National Laboratory (LANL) (1987)**
- **Research Associate, LANL, 87-89**
  - **Principle Investigator of 3 experiments at LANL**
- **Research Associate, Fermilab, 89-91**
  - **Lead Author and only RA on experimental proposal E789**
- **Staff Scientist Fermilab, 91-Present (Scientist-II)**
  - **Physicist in Charge, Fermilab Experiment E789, 1992-93**
  - **Main Injector Department**
    - **Main Injector and Recycler Accelerator Physics Team 1991-2003**
    - **Member of the Fermilab Run Coordinator team, 1994-95**
    - **Head of the Main Injector Commissioning, Fermilab, 1998-99**
    - **Head, Main Injector Department, Fermilab, 1999- 2003**
      - **Head of the Recycler Ring Commissioning, 2001-03**
  - **Program Leader, ILC R&D at Fermilab, 2003-2005.**
  - **Deputy ILC/SRF Program Director, Fermilab, 2005-2010**
  - **Project-X, International Collaboration Coordinator, 2010-Present**
- **Adjunct Professor, University of Delhi**
  - **Supervise Ph.D. student, Chair Ph.D. Thesis committee**



Fermilab

# My Laboratory: Fermilab



The Fermilab Tevatron has now passed on the energy frontier to LHC, following 25 years as the highest energy particle collider in the world.

Fermilab operates the highest power long baseline neutrino beam in the world. But will face stiff competition from J-PARC

To Soudan





Fermilab

# India Collaboration Development



- **In 2002, International Linear Collider**
  - Discussed collaboration with Prof. V. S. Ramamurthy
  - Nov. 2003 Indian and US Institutions Interaction meeting
    - 19 US Scientists and managers came to this meeting and site visit
  - 2004 DAE and DST formed a working group to develop collaboration, all DAE lab directors were member
  - 2004, SRF was chosen as the technology for ILC
  - 2006 Umbrella MOU signed
  - 2007 an Addendum to collaborate on SRF was signed
    - Pitamber Singh and Jishnu Dewedi visited Fermilab
- **In 2008, Fermilab and US attention shifted from ILC to High Intensity Proton Accelerator**
  - Dr. Pier Oddone, Director, Fermilab, wrote a letter to Dr. Anil Kakodkar, Secretary, DAE inviting India to collaborate on High Intensity Proton Accelerator
  - Dr. Kakodkar sent a very positive response
  - Jan 2009, During the signing of the Addendum MOU III at Indore, Dr. Kakodkar and Dr. Oddone met privately
    - Concept of “Total Project Collaboration” emerged
    - Fermilab changed the HIPA design from Pulsed to CW
    - Supplement I to Addendum MOU III was developed
    - Oct 2009, Dr. Banerjee, Dr. Bhandari and Dr. Sahni, visited Fermilab
    - Jan 2010, Dr. Dennis Kovar, Assistant Secretary, US-DOE-HEP visited DAE
      - Idea of three Phase Collaboration Developed
    - Brinkman, Director, US-DOE-OS met with Dr. Banerjee and Dr. Grover several time



# Status: MOU and Agreement



- In Feb 2010, Shekhar Mishra made first US government presentation on behalf of DOE at DAE-OYC
  - US-India Civil Nuclear Working Group
- May 2010, Dr. Banerjee requested US-DOE for a Road Map for this collaboration
  - Mr. Dennial Poneman Deputy Secretary, Dr. Brinkman, Dr. Miller, Dr. Banerjee and Ms. Meera Shankar, Indian Ambassador met in Washington to discuss this Road Map
  - Supplement I to Addendum MOU III and additional MOUs were discussed
  - Dr. Poneman and Dr. Banerjee agreed to develop DOE-DAE agreement
- Oct 2010 IIFC meeting to discuss these documents in detail
  - Dr. Banerjee gave IIFC action items for Indian XII Plan.
- US-DOE and Indian-DAE are working on the text of an agreement for the Phase III of this collaboration.
  - US-DOE has obtained Circular-175 for this collaboration
    - The Circular 175 procedure seeks to confirm that the making of treaties and other international agreements by the United States is carried out within constitutional and other legal limitations, with due consideration of the agreement's foreign policy implications, and with appropriate involvement by the State Department.
  - Fermilab, US-DOE, US-SD,... has gone over this collaboration with India
    - A high level agreement document is with DAE at present
    - As soon as that is signed, we will develop addendums to this agreement for Phase-III
      - Dr. Kakodkar and Dr. Banerjee has already discussed the high level contents with Dr. Oddone, Dr. Kovar and Dr. Brinkman



# Indian Management of IIFC

- In Summer 2010, Dr. Srikumar Banerjee, Secretary, Department of Atomic Energy, India, has formed two Indian committee for the Indian side of IIFC management.
  - **DAE-ACFAP (Apex Committee to Formulate Action Plan)**
    - Dr S. Banerjee- Chairman
    - Dr. S. Kailas, Convener
  - **IC-IIFC (Internal Committee for Indian Institutions & Fermilab Collaboration (IC-IIFC) with participating institutions)**
    - Bhabha Atomic Research Centre
    - Raja Ramanna Centre for Advanced Technology
    - Variable Energy Cyclotron Centre
    - Inter-University Accelerator Centre
    - Indira Gandhi Centre for Atomic Research
      - Dr. R. K. Bhandari, Chairman
      - Dr. V. C. Sahni, Convener
      - Dr. P. Singh, Member-Secretary
- **IC-IIFC to develop the technical part of this collaboration**
  - Working with IC-IIFC we have developed several documents, 3 additional Addendum MOUs and Project Documents



Fermilab

# IIFC Joint Management

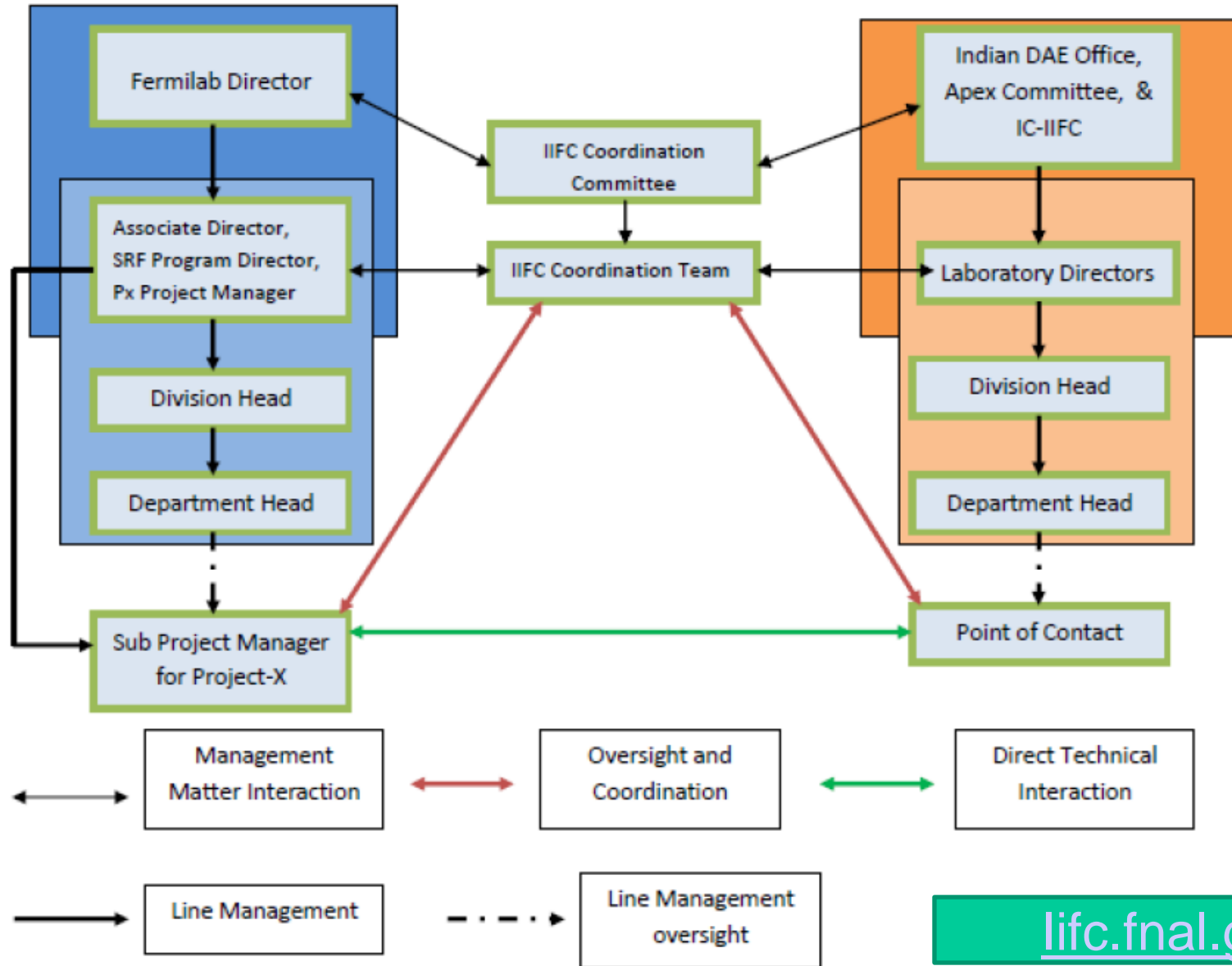

[lfc.fnal.gov](http://lfc.fnal.gov)



# Px: Collaboration Plan



- A multi-institutional collaboration has been established to execute the Project X RD&D Program.
  - Being organized as a “national project with international participation”.
    - Fermilab as lead laboratory with ultimate responsibility
    - International participation via “in-kind” contributions, established through bi-lateral MOUs.
    - Collaborators assume responsibility for components and sub-system design, development, and construction.

## – National Collaboration

### MOU signatories:

ANL	ORNL/SNS
BNL	MSU
Cornell	TJNAF
Fermilab	SLAC
LBNL	ILC/ART

### • International Collaboration MOU

#### Indian Institutions:

BARC/Mumbai  
 IUAC/Delhi  
 RRCAT/Indore  
 VECC/Kolkata





# Indian Nuclear Program



- Indian 3<sup>rd</sup> Stage program focuses on utilization of thorium.
- Paths of converting Thorium into fissile material:
  - Fast Breeder Reactor
  - AHWR
  - Accelerator Driven System
- ADS is the only system that could remove the Indian dependence on foreign Uranium.
- In ADS high-energy proton beam generates neutrons directly through spallation reaction.
  - Efficient Accelerator
  - Accelerator → Spallation Target
  - Reactor

ram

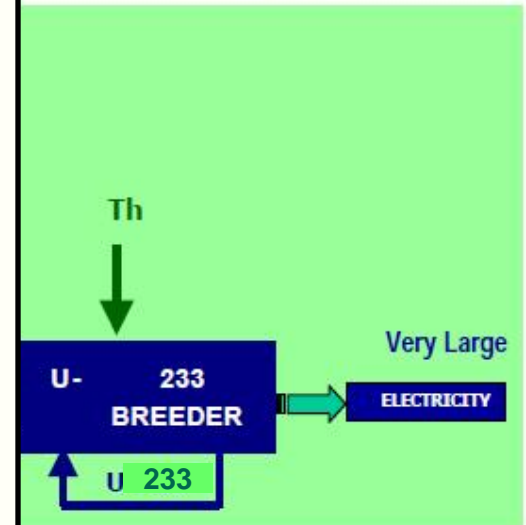
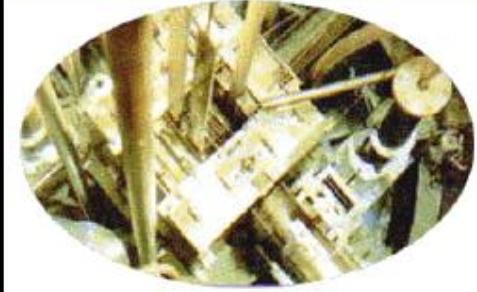

STAGE 3



Fermilab

# Beam Energy and Power

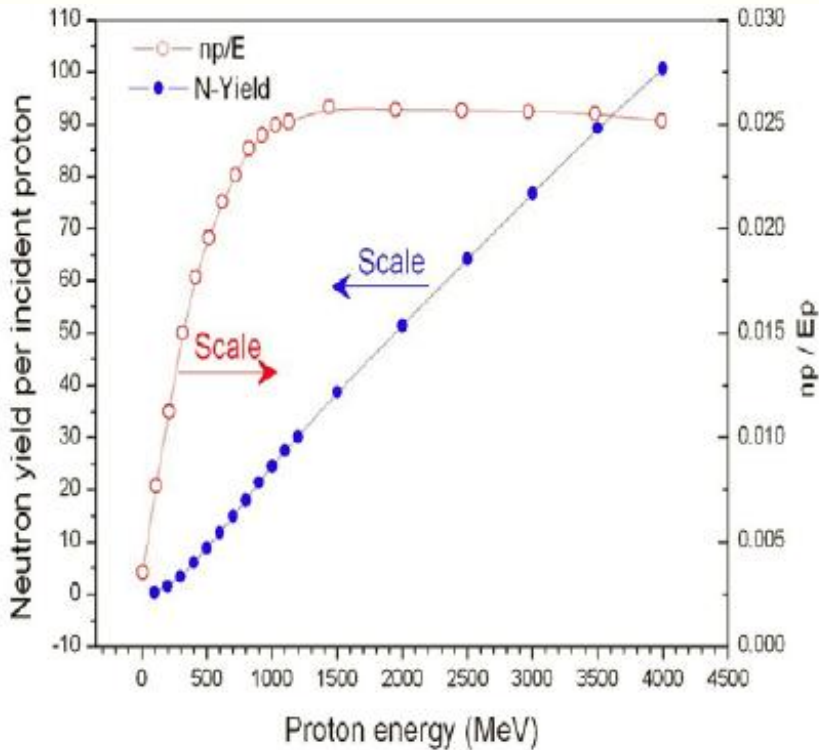

Neutron yield as a function of proton energy for one set of target and moderator condition

Beam Energy 1-2 GeV

Beam power needed to drive a 0.8 GW ADS sub-critical core as a function of  $k_{src}$ , the effective neutron multiplication factor.

Beam Power  $\rightarrow$  1-2 MW

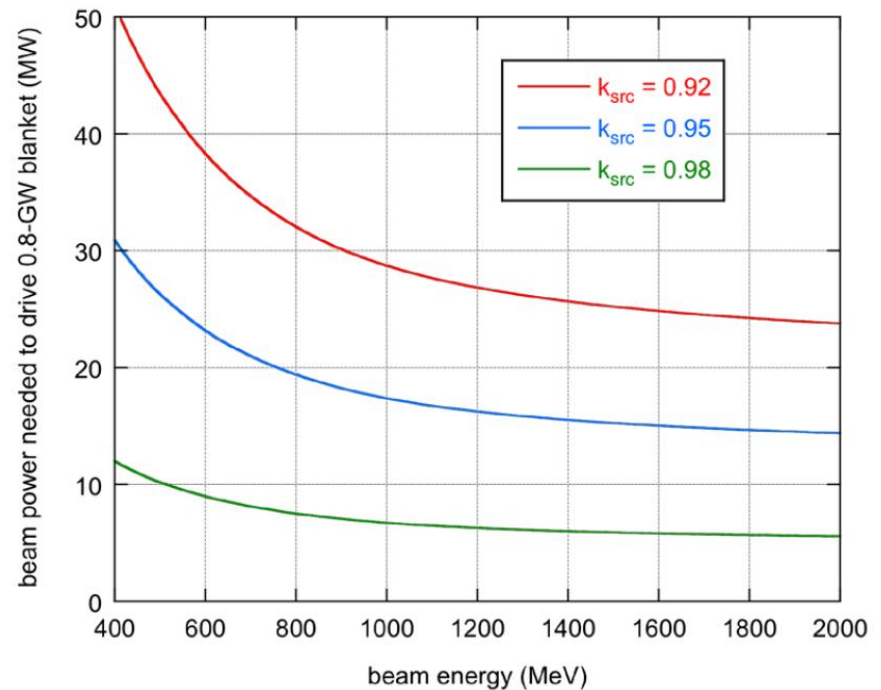

# Accelerator Requirements

Beam Parameter	Parameter value or range for the Nuclear Energy Demonstration Experiment
Beam Power	1-2 MW
Beam Energy	1-2 GeV
Beam Time Structure	Continuous Wave
Beam trips ( $1 < t < 10$ Sec)	$< 5000$ per year
Beam trips ( $10 \text{ sec} < t < 5$ mins)	$< 2500$ per year
Beam trips ( $t > 5$ mins)	$< 50$ per year
Availability	$\triangleright 50\%$



Fermilab

# Key Technology Issues

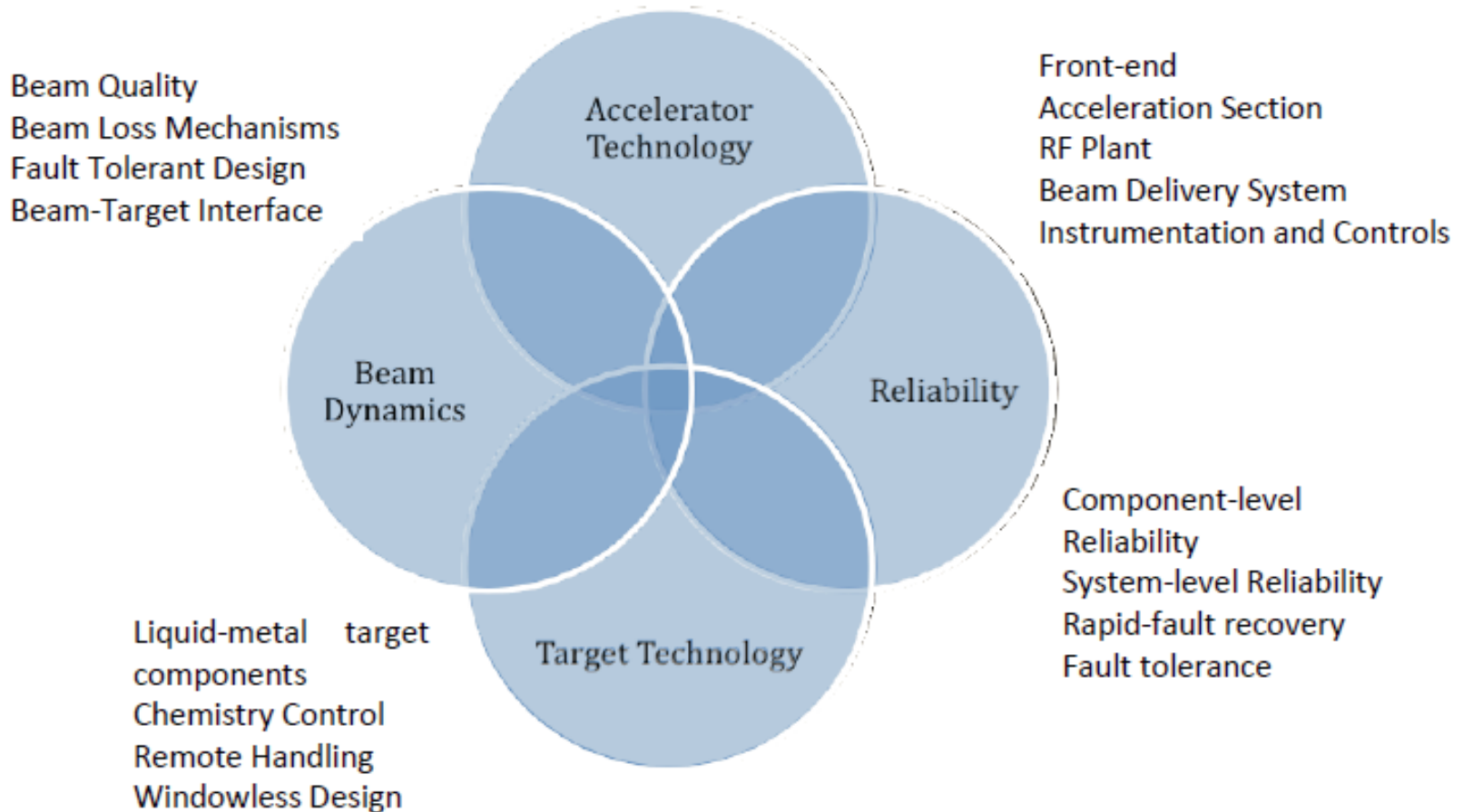

Technology Demonstration Facility



Fermilab

# Technology Demonstration



		Transmutation Demonstration	Industrial-Scale Transmutation	Power Generation
Front-End System	Performance	Green	Green	Green
	Reliability	Yellow	Yellow	Red
Accelerating System	RF Structure Development and Performance	Green	Green	Green
	Linac Cost Optimization	Green	Yellow	Yellow
	Reliability	Yellow	Yellow	Yellow
RF Plant	Performance	Green	Green	Green
	Cost Optimization	Green	Yellow	Yellow
	Reliability	Yellow	Yellow	Red
Beam Delivery	Performance	Green	Green	Green
Target Systems	Performance	Green	Yellow	Yellow
	Reliability	Yellow	Yellow	Yellow
Instrumentation and Control	Performance	Green	Yellow	Yellow
Beam Dynamics	Emittance/halo growth/beamloss	Green	Yellow	Yellow
	Lattice design	Green	Yellow	Yellow
Reliability	Rapid SCL Fault Recovery	Yellow	Red	Red
	System Reliability Engineering Analysis	Yellow	Red	Red

**Green:** Ready, **Yellow:** May be ready, **Red:** More R&D

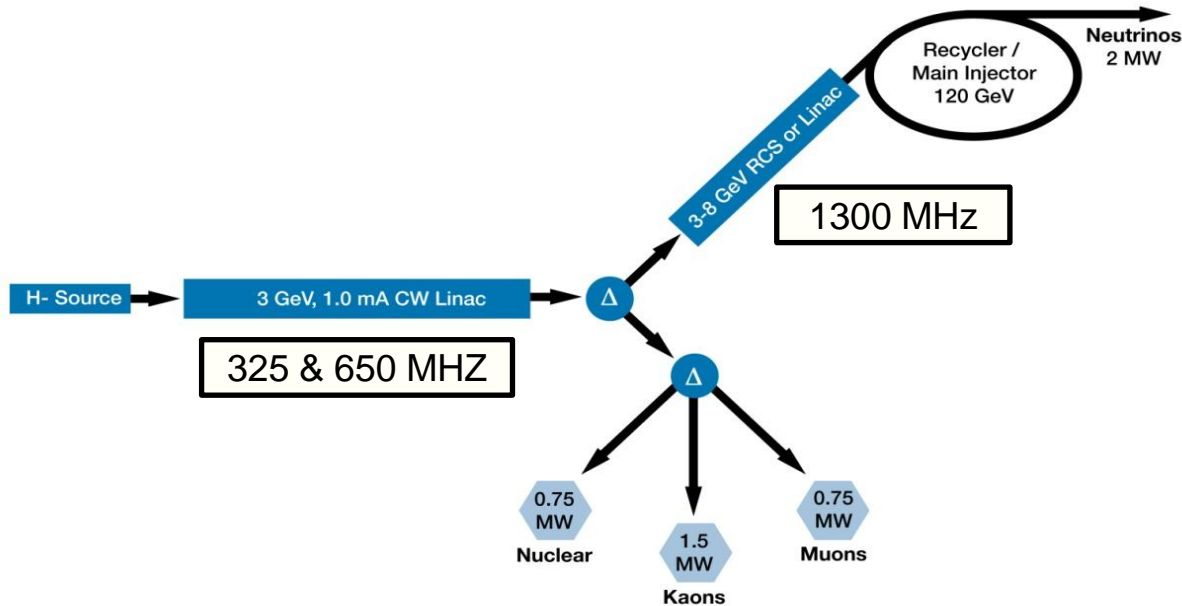

- **3-GeV, 1-mA, CW linac, 325 and 650 MHz, provides beam for rare processes, nuclear and energy programs**
  - ~3 MW; flexible provision for beam requirements supporting multiple users
  - < 5% of beam is sent to the Main Injector
- **Reference Design for 3-8 GeV acceleration: pulsed linac**
  - Linac would be 1300 MHz with <5% duty cycle



# Next 10-15 yrs Strategy



- A multi-MW Proton Source with 1-2 GeV, ~2MW, CW proton beam could be the **accelerator, spallation target, and accelerator, target and reactor interface, technology demonstration** project corresponding to 10s of MW electrical power production.

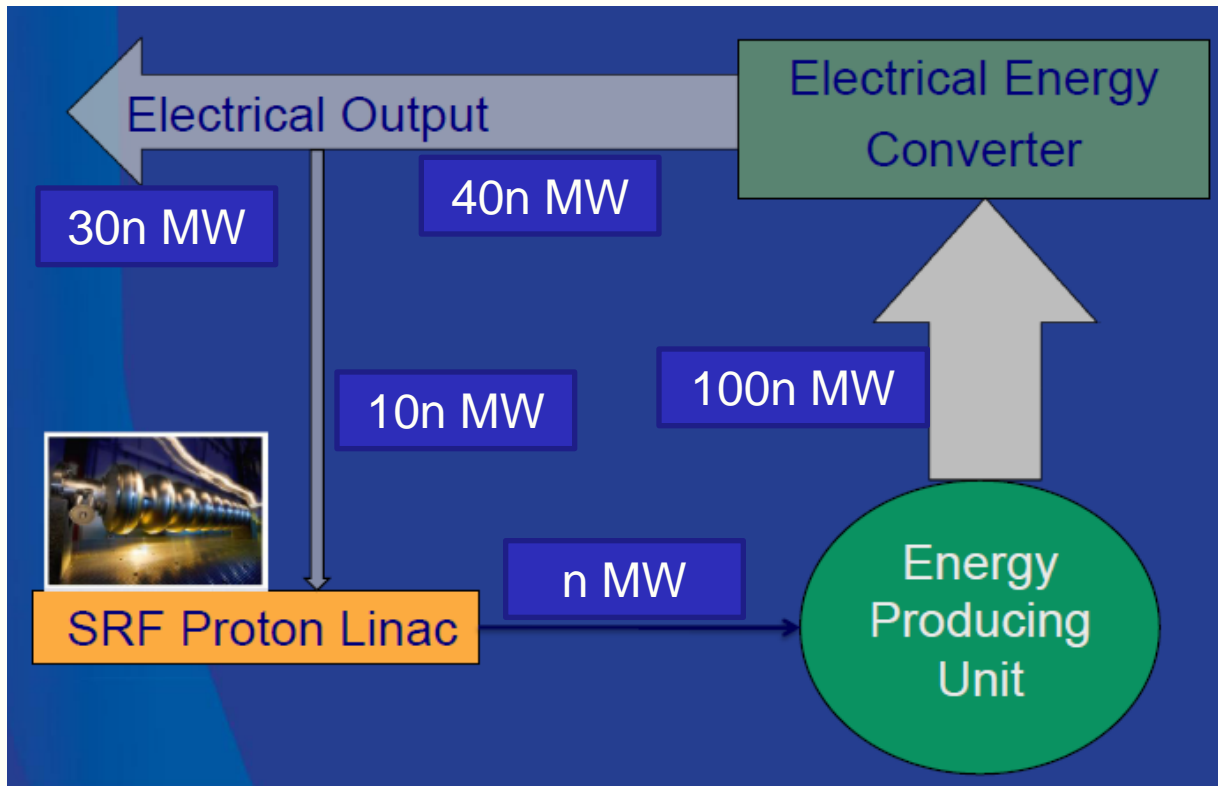



Fermilab

# SRF Accelerator Design

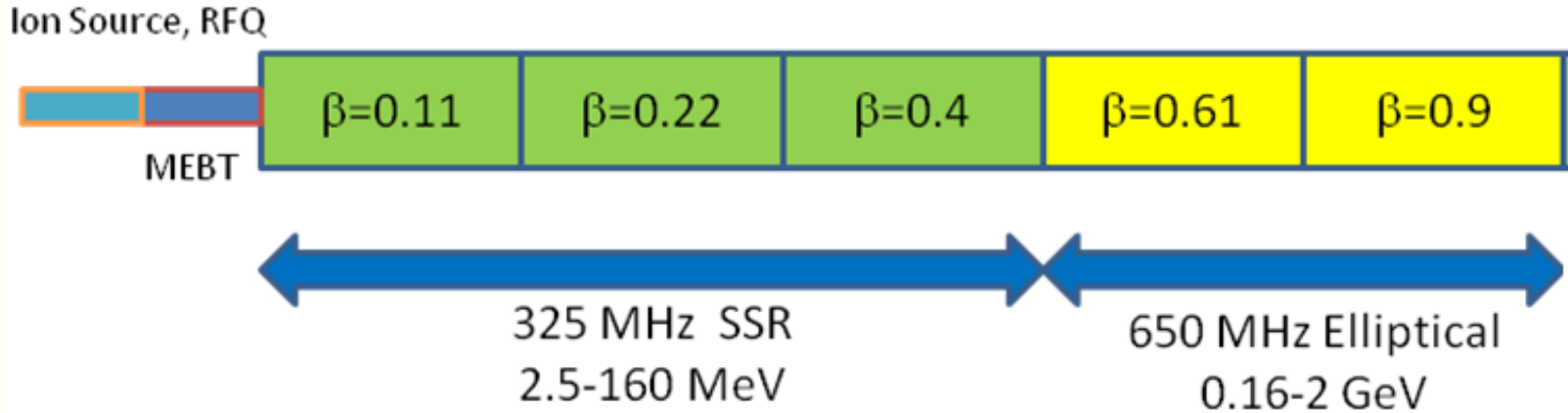

- Ion source
- Radio Frequency Quadrupole
- Medium Energy Beam Transport (MEBT), including the bunching cavities
- Three accelerating sections based on 325 MHz Single-Spoke Resonators (SSR)
- Two accelerating sections of 650 MHz elliptical cavities.





# Radio Frequency Quadrupole



- The Radio Frequency Quadrupole is placed after the ion source for simultaneous
  - focusing, bunching and accelerating the low energy ion beams with high transmission and good beam quality (low emittance).
- The Beam dynamics of 2.5 RFQ accelerator for HIPA has been studied for operating frequencies of 325 and 162.5 MHz using the codes PARMTEQM/TOUTATIS. ([Rao, BARC](#))
  - The simulations have been done using two different techniques: LANL technique and Non-adiabatique technique.

Table 3: Parameters of 162.5 MHz RFQ

Parameters	Values	Units
Ions	H-	
Frequency	162.5	MHz
Vane voltage	108	kV
Peak Field	21.5	MV/m
R0	0.72	cm
Transmission (p)	98.9	%
Length	4.01	cm

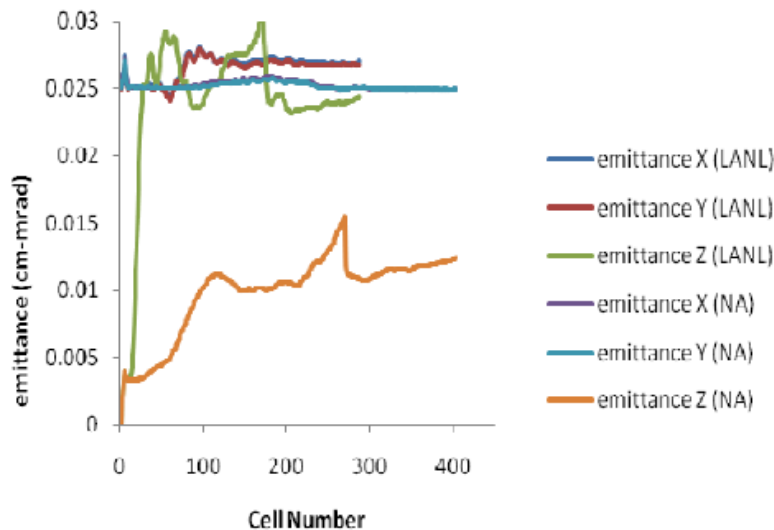

Figure 4: Evolution of emittances along RFQ.



Fermilab

# RFQ at Fermilab



- Fermilab is developing a High Intensity Front End Test Facility for HIPA.
  - Indian colleagues (BARC) are participating in this activity.

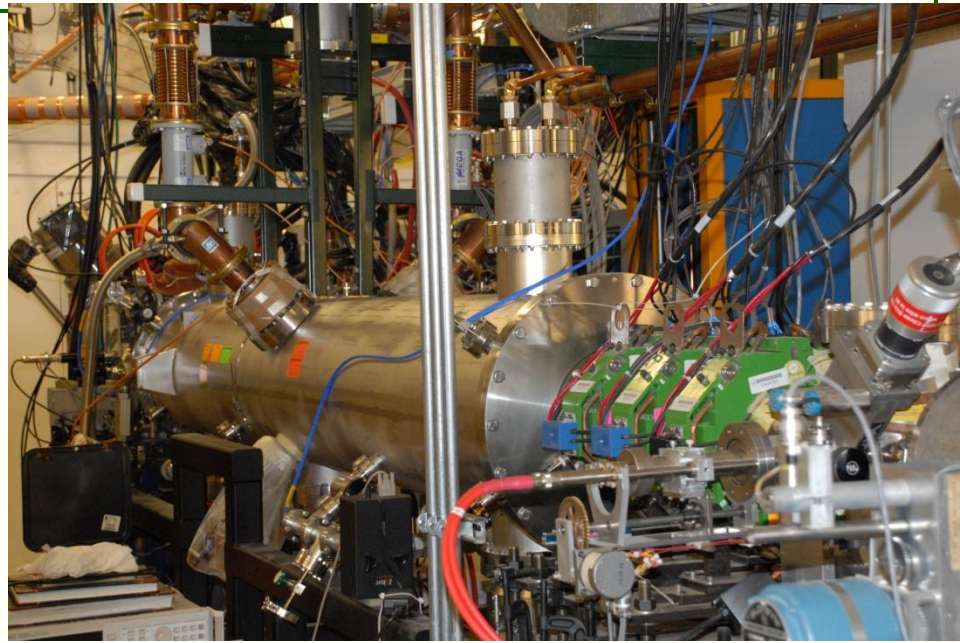
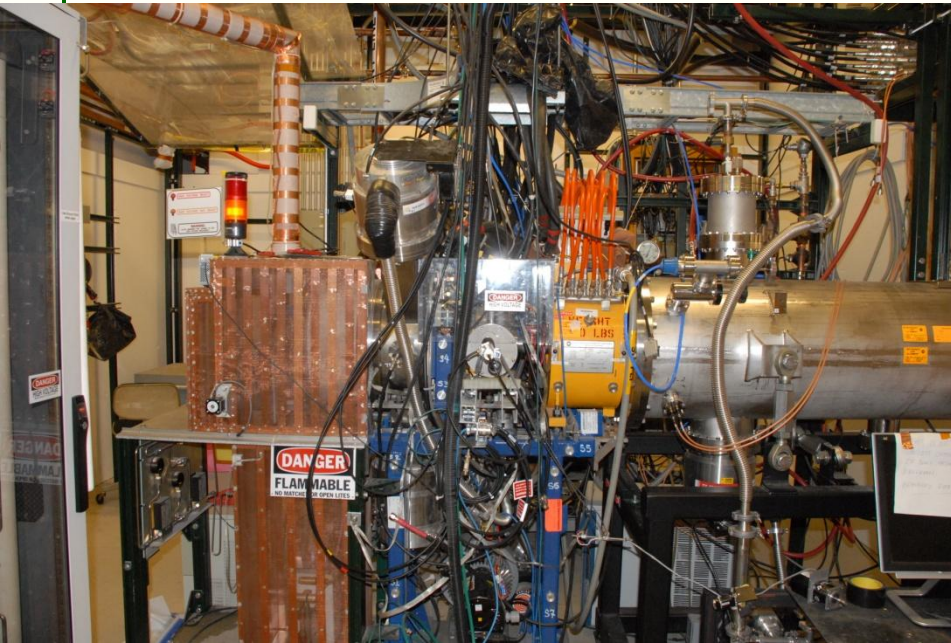

- BARC could propose to fabricate two CW-RFQ of the design that is being developed in collaboration with Fermilab.
  - Send one to Fermilab and test it with beam



Fermilab

# SRF HIPA Accelerator Layout

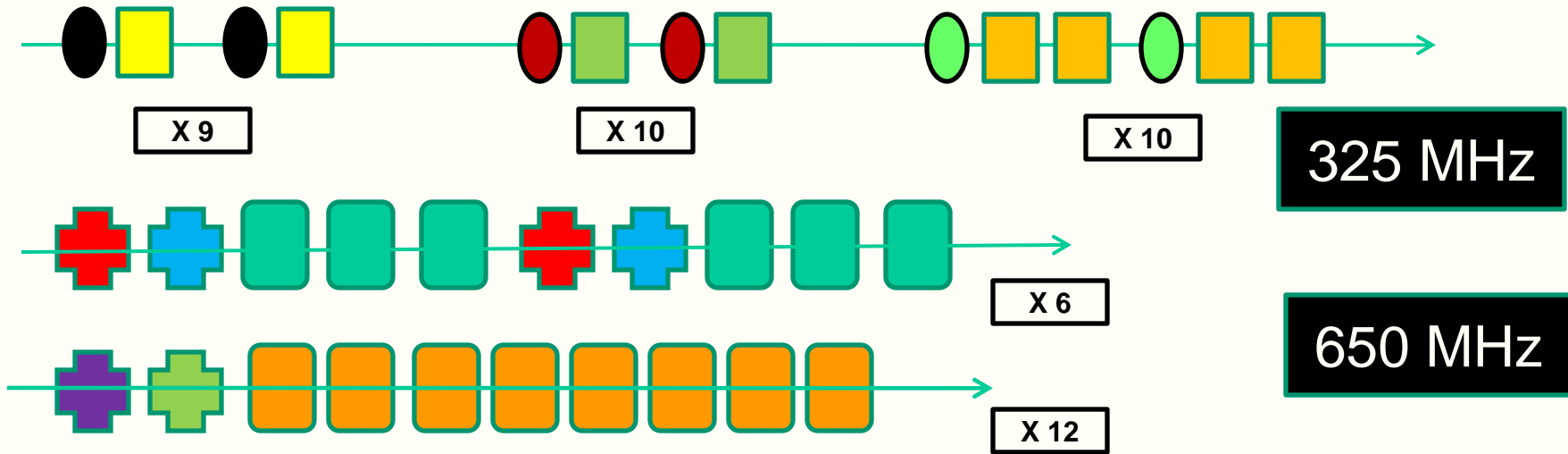

- Extensive design of the SRF accelerator layout and beam optics has been carried using five families of cavities

- Increase the acceleration efficiency
  - Minimize the cost
- Reduce the beam loss
  - Operation at higher intensity



# HIPA Design and Beam Dynamics



- **Accelerator design and its interplay with engineering:**
  - The SC linac lattice is independent of beam current, wave numbers (phase advance per unit period length) of transverse and longitudinal oscillations should be smooth through the SC linac and should change only gradually in order to avoid possible mismatch.
  - Longitudinal phase advance (under zero beam condition) is smooth without discontinuities throughout the SC linac to avoid halo excitation.
  - Length of the focusing period is kept short, especially in the low energy section where space charge dominates.
  - Matching between each cryomodule is smooth to avoid halo generation and emittance growth.
    - Beam matching is achieved by adjusting the gradients and phases of the outermost elements of each side of the transition.

## Lattice V 3.8.4 (650 MHz to 3 GeV)

TraceWin - CEA/DSM/Irfu/SACM

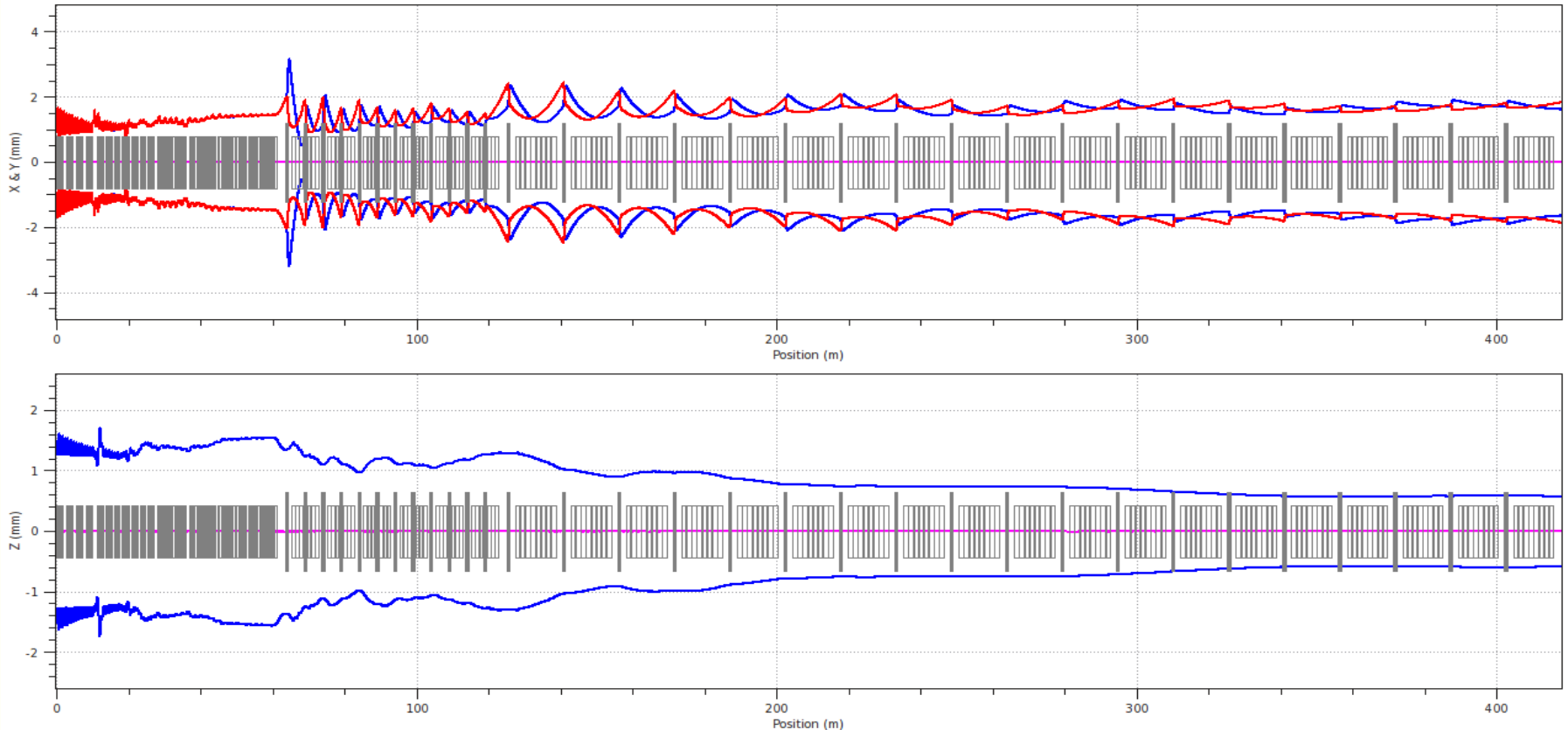

**TOP: Transverse horizontal and vertical envelopes**  
**BOTTOM: Longitudinal envelope**



Fermilab

# Beam Dynamics

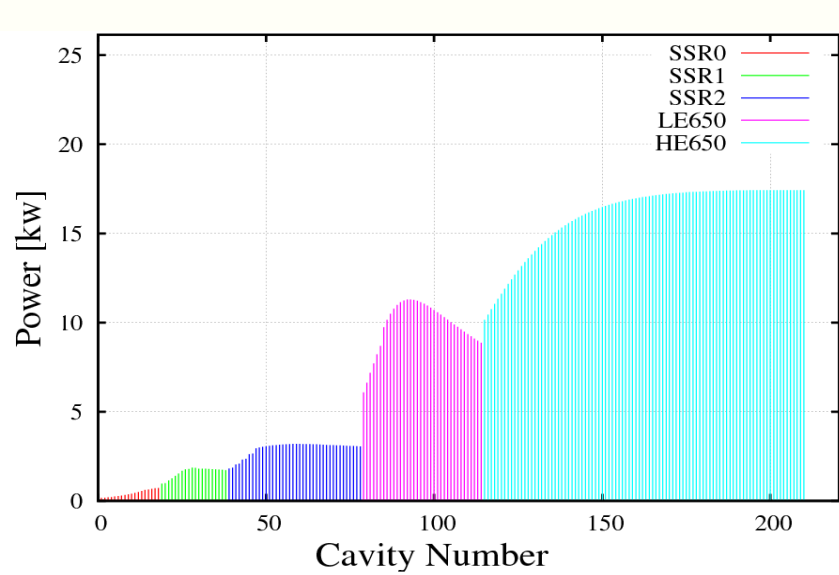

RF power consumption per cavity

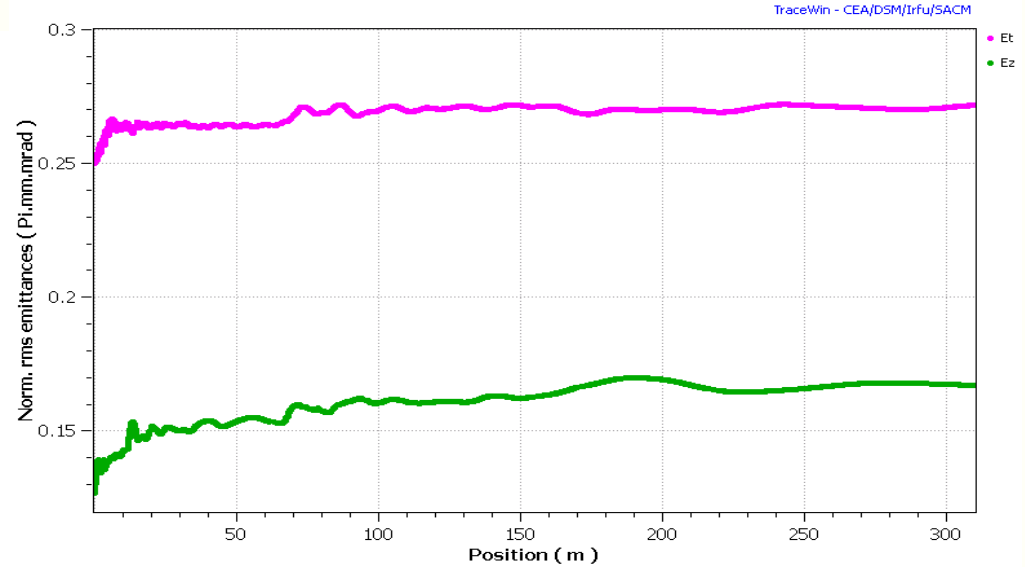

Normalized transverse (magenta) and longitudinal (green) emittances

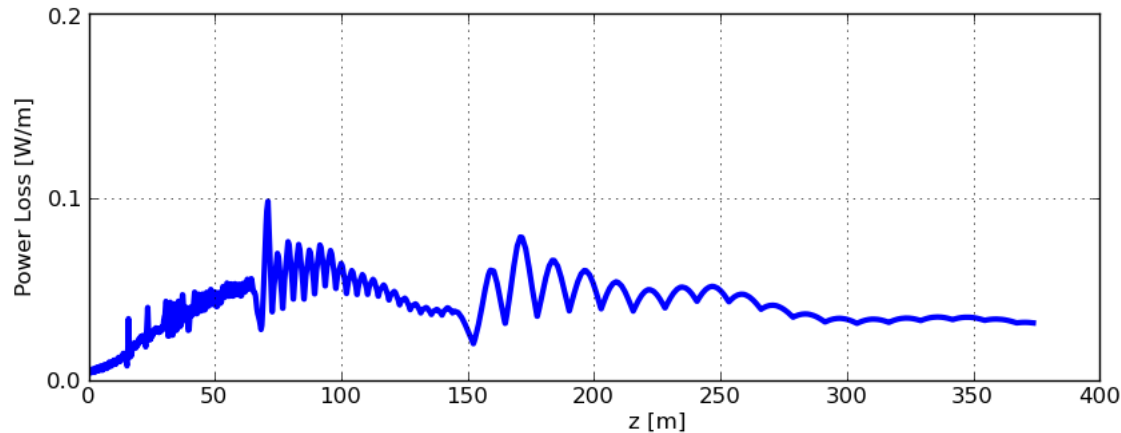

Beam power losses per unit length caused by intra-beam stripping



# Accelerator Design and Beam Dynamics



- Matching between each cryomodule is smooth to avoid halo generation and emittance growth.
  - Beam matching is achieved by adjusting the gradients and phases of the outermost elements of each side of the transition.
- Lattice design is robust to allow for spread in designed parameters
  - Spread in cavity gradient, operation of linac with failed beam line elements, misalignments etc.

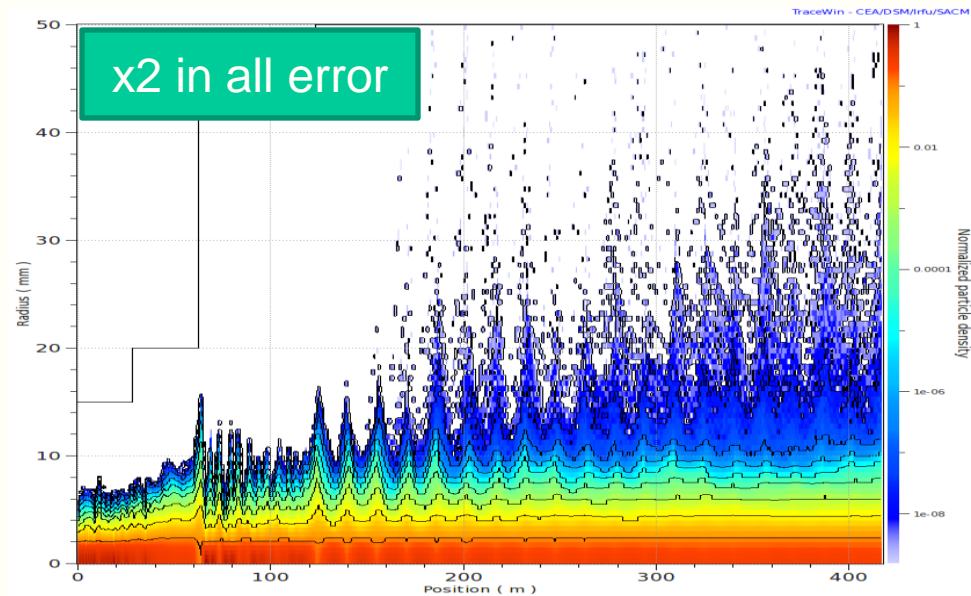
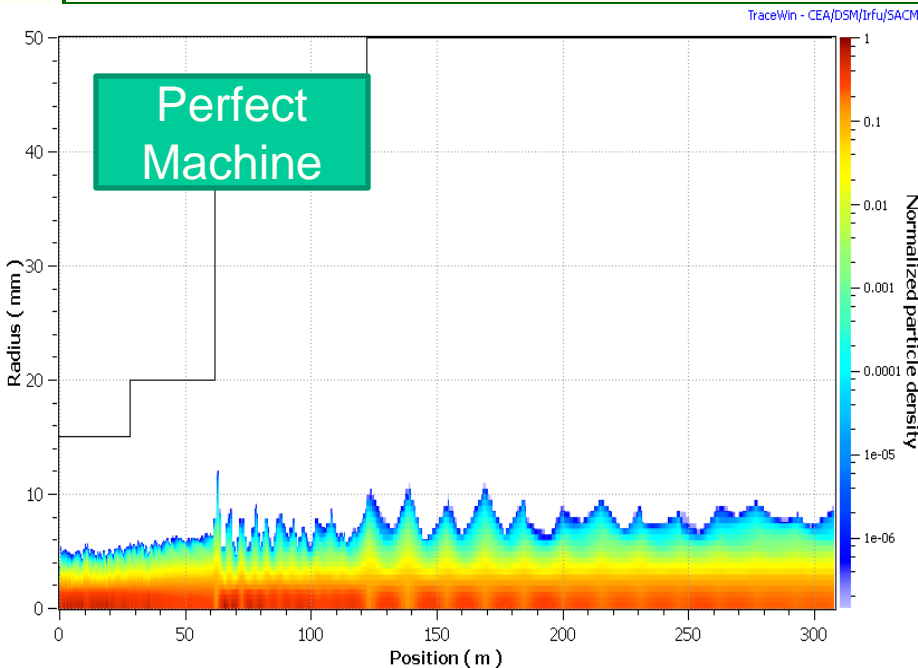



Fermilab

# Steering Error Correction

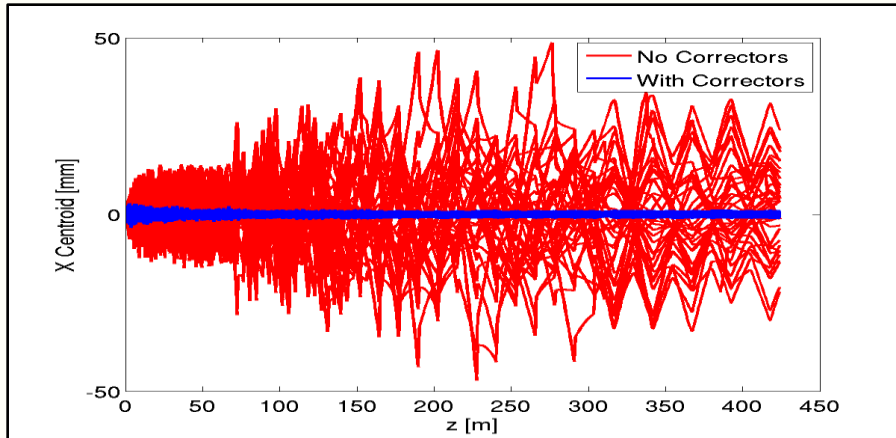

## Beam Centroid Position

**RED**: steering correction **OFF**

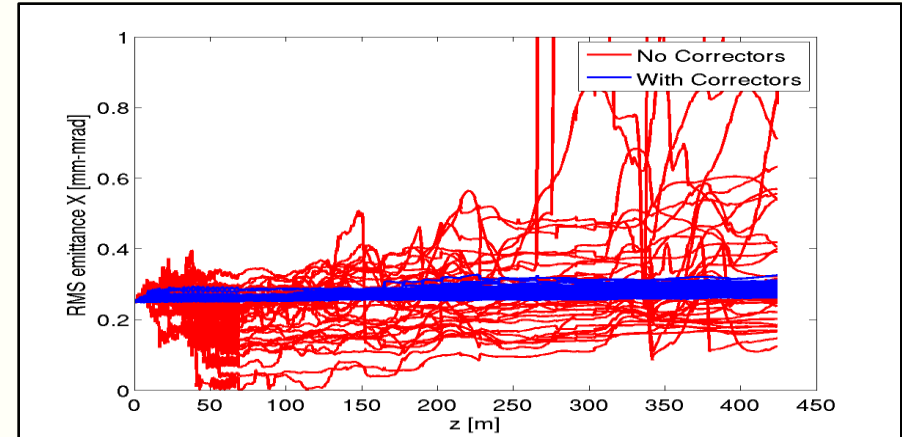

## Transverse Emittance

**BLUE**: steering correction **ON**

- Misalignments  $\pm 1$  mm for all elements (specification  $\pm 0.5$  mm)
- RF jitter of  $0.5^\circ \times 0.5\%$  in the front-end &  $1^\circ \times 1\%$  RF jitter in the high-energy part was implemented.
- 100 seeds and 1 million macro-particles per seed.
- 1 corrector, + 1 BPM per solenoid/doublet/quad; BPM resolution =  $30 \mu\text{m}$
- Beam centroid is corrected to  $\pm 1$  mm; Emittance increase  $< 20\%$ .
- The uncorrected seeds predict losses above 100 W/m; corrected – no losses





- Working gradient of the cavities are limited by the peak surface magnetic field & cryogenic losses.
  - Maximum surface field which is chosen to protect the RF cavity from quenching.
    - 60 mT for all the 325 MHz cavities
    - 70 mT for all the 650 MHz cavities.
  - Cryogenic losses per cavity should be less than 25 W.

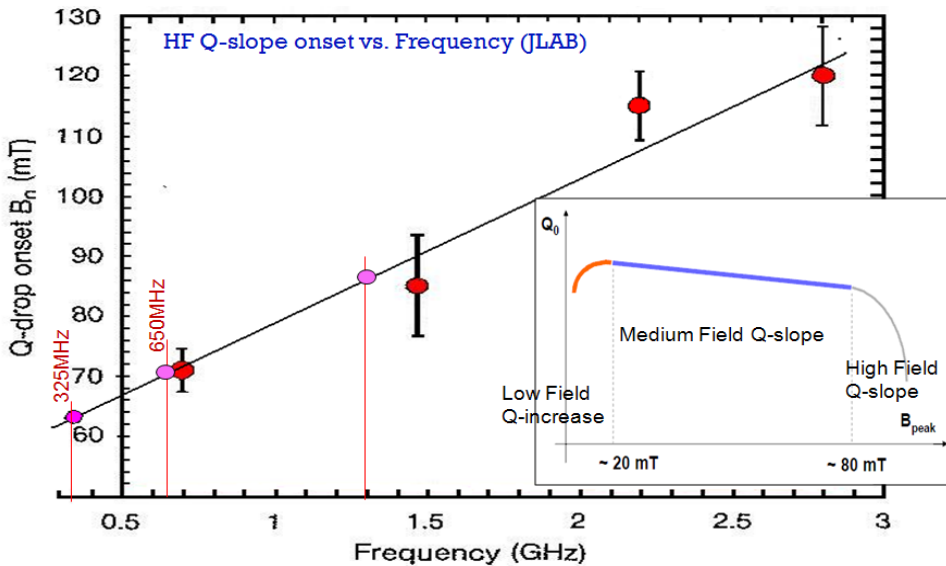

High field Q-slope versus frequency

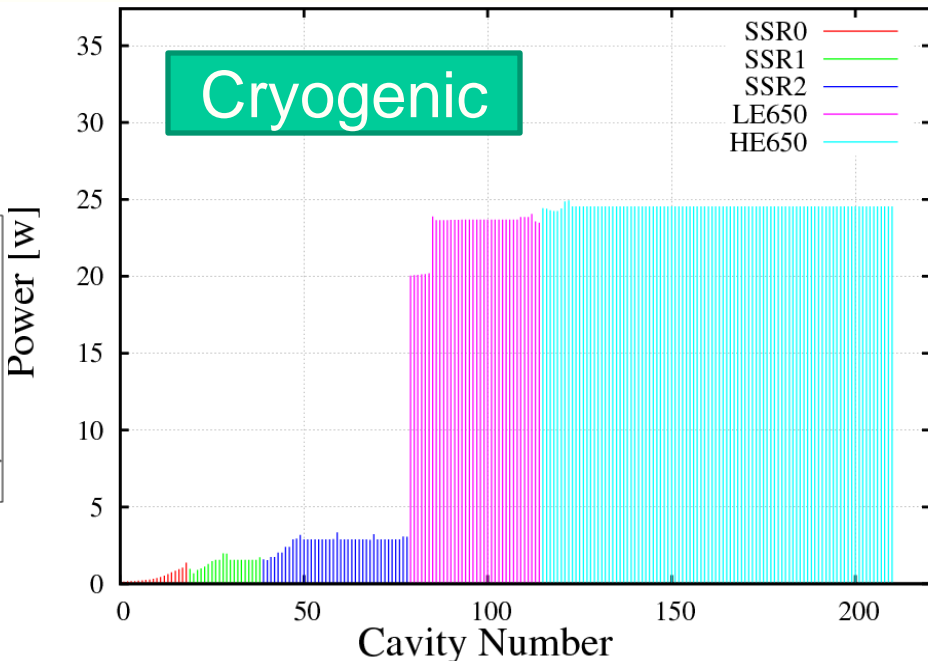



# Baseline Design of HIPA

Ion source, RFQ

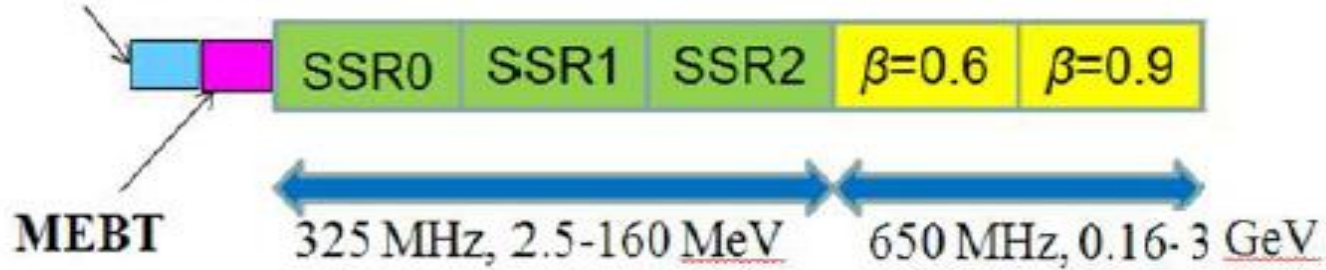

Arun

	SSR0	SSR1	SSR2	LE	HE	HE (2-3Gev)
# Cavities	18	20	40	36	96	56
# Solenoids	18	20	20	0	0	0
# Quadrupoles	0	0	0	24	24	14
# Cryomodules	1	2	4	6	12	7
Length (m)	11.38	16.8	34.86	61.93	184.8	107.8
Position (m)	0	11.38	28.18	63.04	124.97	309.77
Period Length (m)	0.61	0.8	1.6	5	15.4	15.4
# periods	18	20	20	12	12	7
Transition Ene (MeV)	10.18	42.57	160.53	515.38	2056	3028
Transition $\beta$	0.146	0.291	0.52	0.763	0.95	0.97

# 325 MHz spoke cavities family

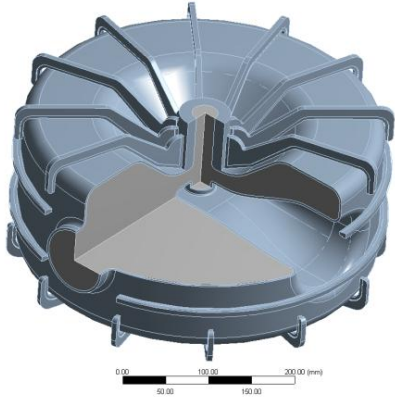

SSR0 - design



SSR1 – prototyping, testing

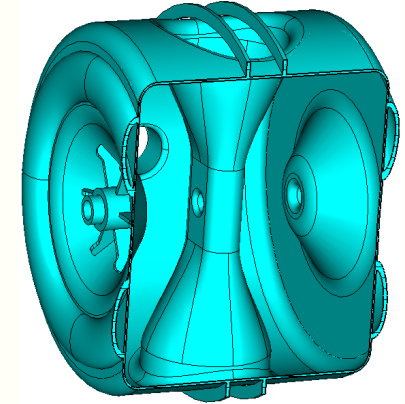
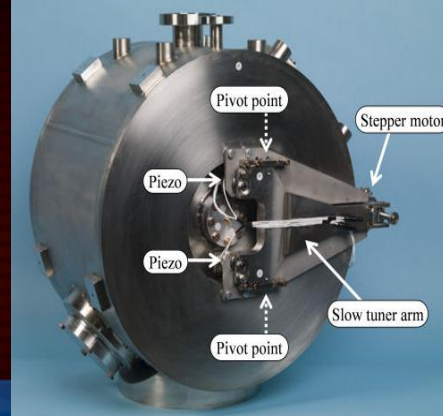

SSR2 - design

## Parameters of the Single-Spoke Resonator cavities

cavity type	$\beta_G$	Freq MHz	Beam pipe $\varnothing$ , mm	$V_{a, \max}$ MeV	$E_{\max}$ MV/m	$B_{\max}$ mT	R/Q, $\Omega$	G, $\Omega$	* $Q_{0,2K} \times 10^9$	$P_{\max, 2K}$ W
SSR0	$\beta=0.114$	325	30	0.6	32	39	108	50	6.5	0.5
SSR1	$\beta=0.215$	325	30	1.47	28	43	242	84	11.0	0.8
SSR2	$\beta=0.42$	325	40	3.34	32	60	292	109	13.0	2.9



# 325 MHz Cavity Result

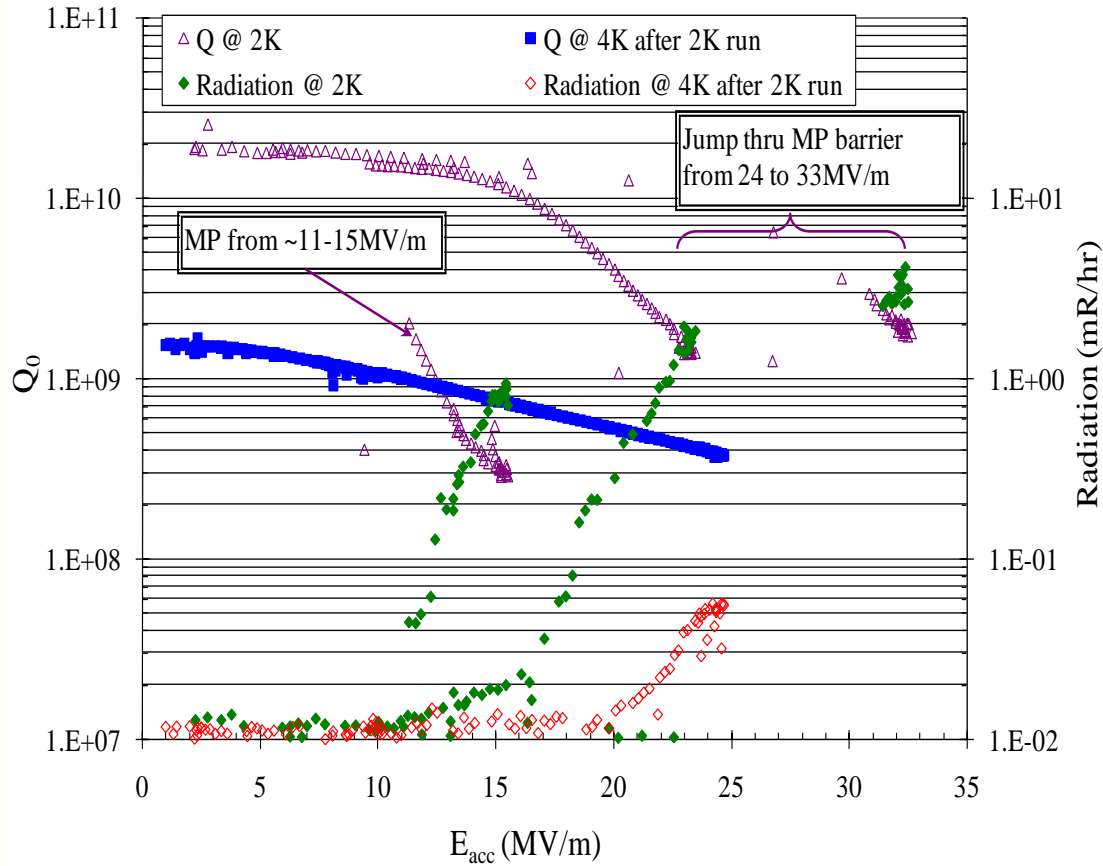

$E_{acc} > 15$  MV/m for  $Q > 1e10$   
HIPA Design needs  $< 10$  MV/m



Fermilab

# 650 MHz Cavity Design Parameters

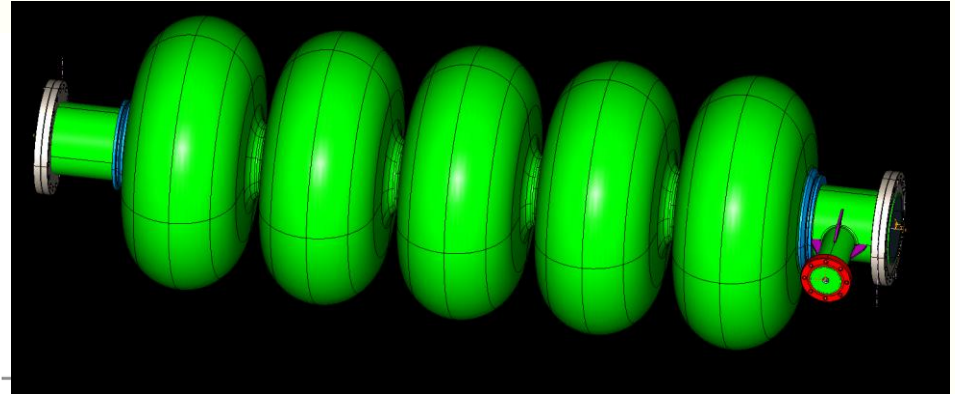
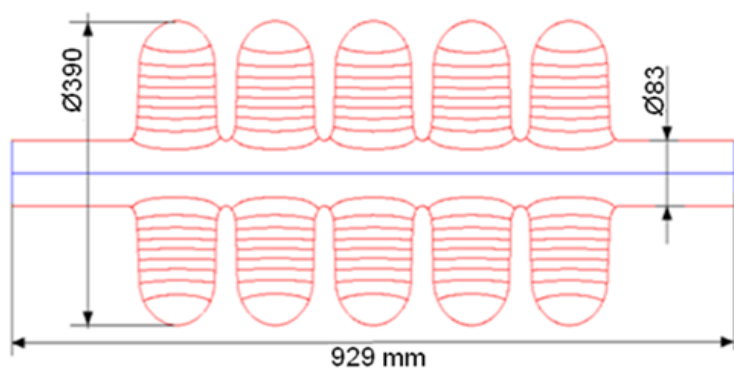

650 MHz:  $\beta=0.61$

650 MHz:  $\beta=0.9$

Arun

$\beta$	0.61	0.9
R/Q, Ohm	378	638
G-factor, Ohm	191	255
Max. gain per cavity, MeV (on crest)	11.3	19.9
Gradient, MeV/m	16.1	19.2
Max. Surface electric field, MV/m	36.4	37.3
$E_{pk}/E_{acc}$	2.26	2
Max surf magnetic field, mT	68	72
$B_{pk}/E_{acc}$	4.21	3.75



Fermilab

# Cavity Accelerating Gradient

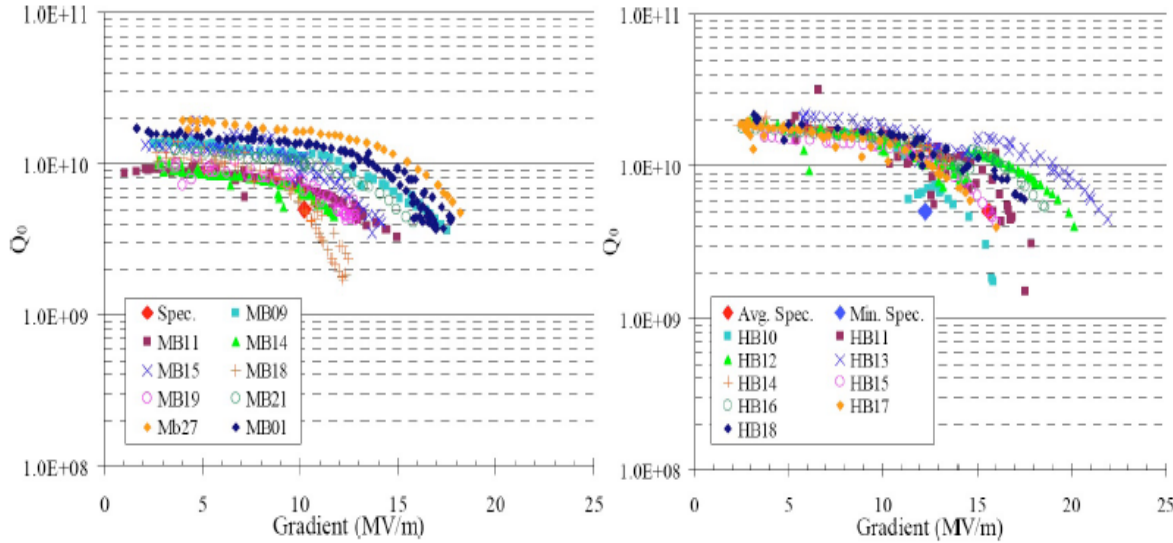

SNS Cavity Result

Cavity Technology Improved in last 10 yrs

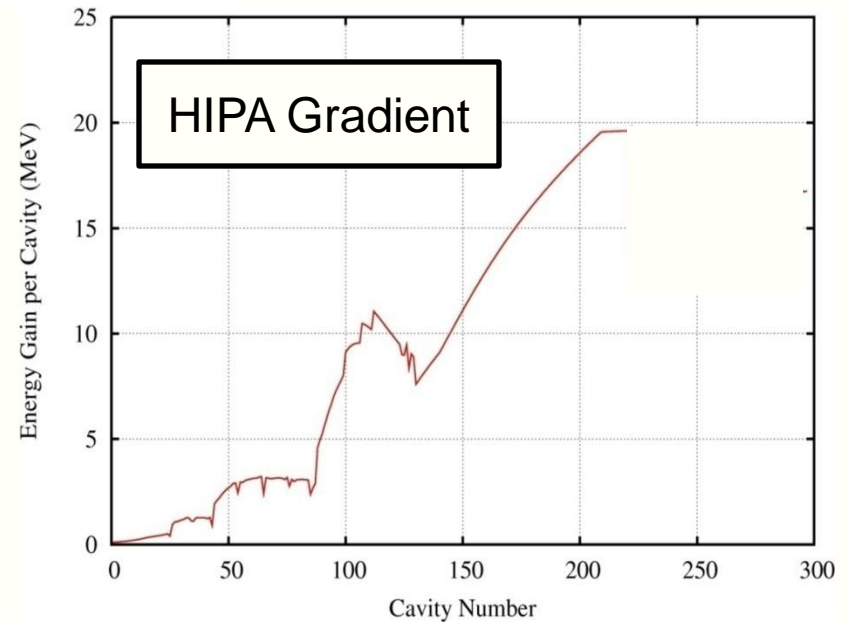
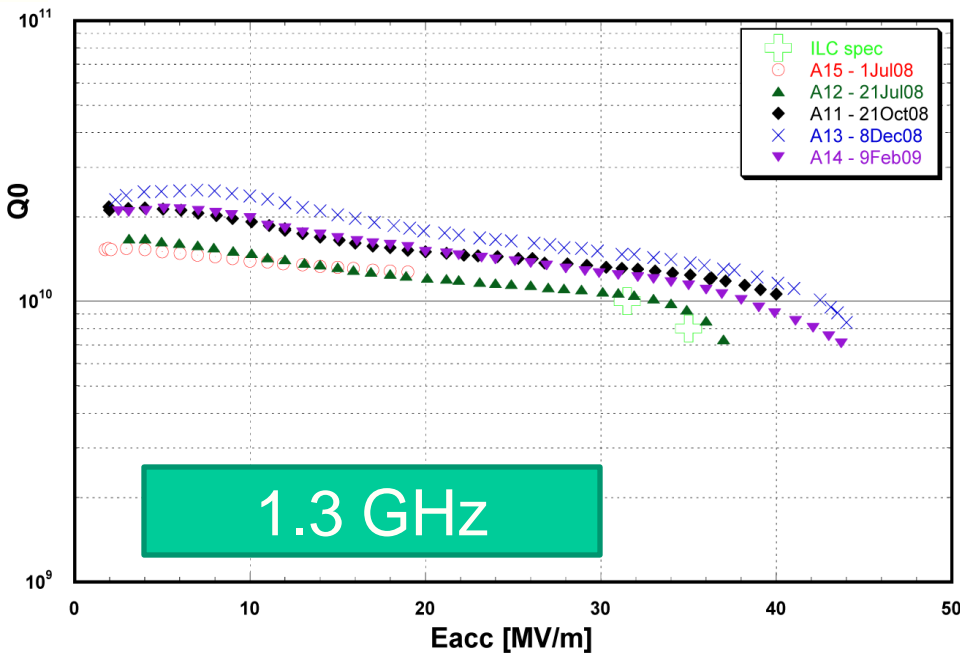



# Niobium → Cryomodule

- **Cavity Design and Fabrication:**
  - Niobium purchased from Industry
  - Nb QA/QC at Laboratory
  - Cavity Fabricated by lab/Industry
  - Cavity QA/QC at Laboratory
- **Cavity Process and low power test at Laboratory**
  - Bulk processing at lab/industry
  - Fine processing, assembly
  - Vertical Test Stand at laboratory
- **Dressed Cavity (He vessel, Tuner, Coupler) at Lab**
  - Start at lab but work to transfer this technology to industry
- **High Power Test of Dressed Cavity at Lab**
  - Horizontal Test Stand
- **Cavity String and Cryomodule Fabrication at Laboratory**
- **Cryomodule Testing at Full Power at lab**
  - Cryomodule Test Stand



Fermilab



# Cavity & Cryomodule Fabrication

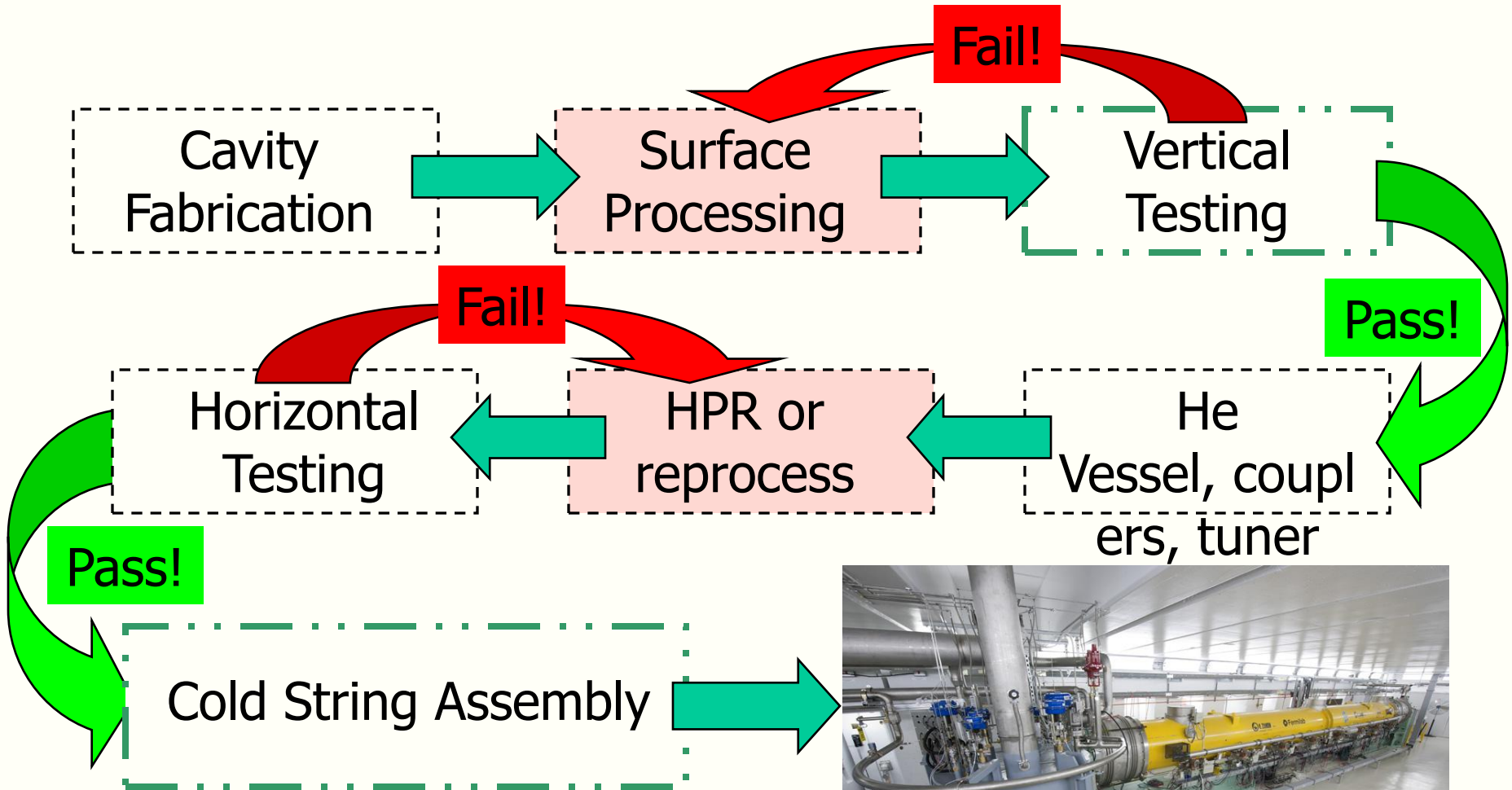





# Cavity Fabrication

- **Under the Addendum MOU III and its Supplement I, Indian Institute and Fermilab Collaboration are jointly developing the design and fabrication of Cavity in India.**
  - **SSR1 Cavity is under fabrication at IUAC**
    - Fermilab transferred all the drawings and tooling information to IUAC.
    - IUAC with a local industry has developed all the infrastructure for this cavity fabrication
    - First two prototype fabrication is progress. These two will be processed and tested at Fermilab.
    - Future processing and testing in India.
    - These will be also dressed (VECC) and 325 MHz power coupler attached in India (BARC).
  - **Elliptical Cavities are under fabrication at RRCAT and VECC**
    - RRCAT engineering have made many visits to Fermilab and US industries for the development of the cavity fabrication infrastructure in India.
    - Development of cavity fabrication technology using 1.3 GHz cavity
    - Excellent prototype results.



Fermilab

# Fabrication of SSR1



- SSR1 cavities are under fabrication at IUAC

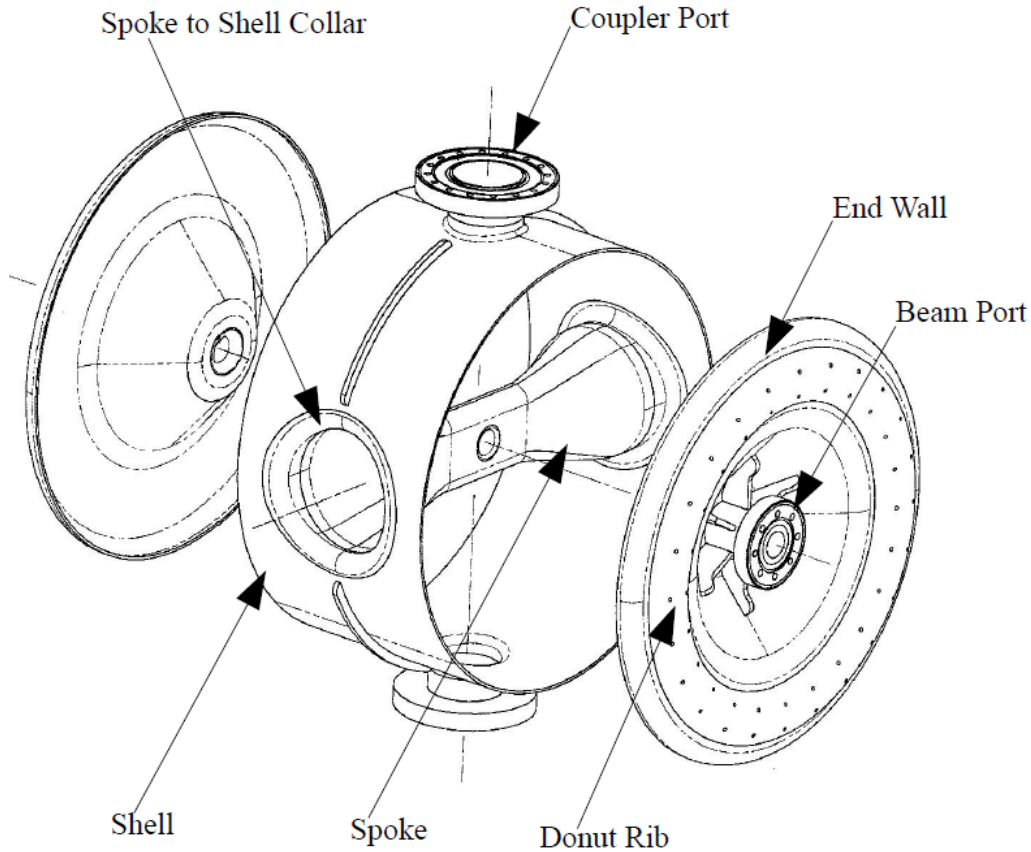

Major components of SSR1 –  $\beta = 0.22$ ,  
 $f = 325$  MHz

Figure 6: Electron beam welding setups showing, (a) above – outer shell, (b) below – spoke halves.



# 1.3 GHz Elliptical Cavity

- RRCAT in collaboration with IUAC is developing elliptical 1.3 GHz cavities
  - Indian engineers were trained at Fermilab and US industry
- Three 1-cell 1.3 GHz ( $\beta=1$ ) cavities have been built by RRCAT, in collaboration with IUAC
  - Two 1-cells were inspected, processed and tested at Fermilab
    - TE1CAT001: Quench at 19 MV/m, Q0 at max gradient  $> 1.5 \text{ E}+10$
    - TE1CAT002: Quench at 21 MV/m, Q0 at max gradient  $> 1.0 \text{ E}+10$
    - TE1CAT002 : 2<sup>nd</sup> test after CBP Quench at 23 MV/m, Q0  $> 1.5 \text{ E}+10$
  - A third has recently been built using improved weld parameters and handling, based on feedback received, and will be processed and tested at Fermilab
- A fourth 1.3 GHz 1-cell and one 1.3 GHz 5-cell Cavity with straight end tubes to be built later this year; to be processed and tested at FNAL



Fermilab

# 1300 MHz Cavity: Forming and Machining



RRCAT: Developed forming tooling & process for 1.3 GHz SCRF cavity.



Forming



Inspection



Machining



Formed Niobium Half cell

**120 T - HYDRAULIC PRESS**





Fermilab

# Equator Welding

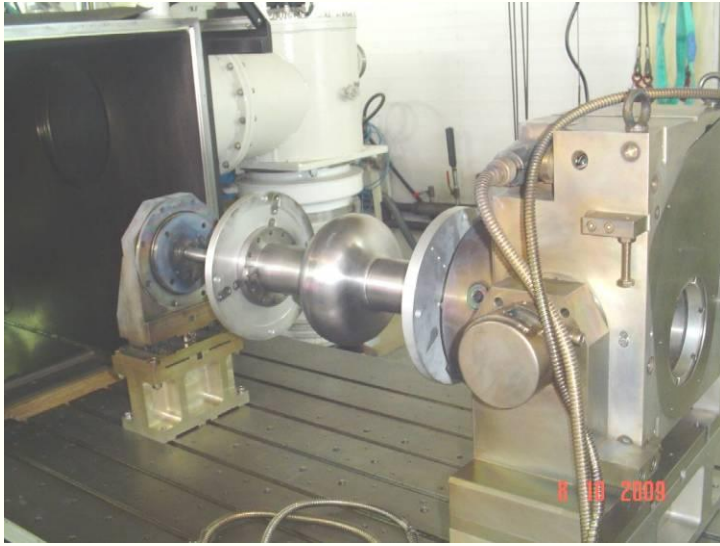

Setting inside IUAC EBW Chamber



Frequency measurement



Mechanical inspection

This work was carried out by RRCAT in collaboration with Fermilab and IUAC.

Significant input was provided by DESY and US Company AES

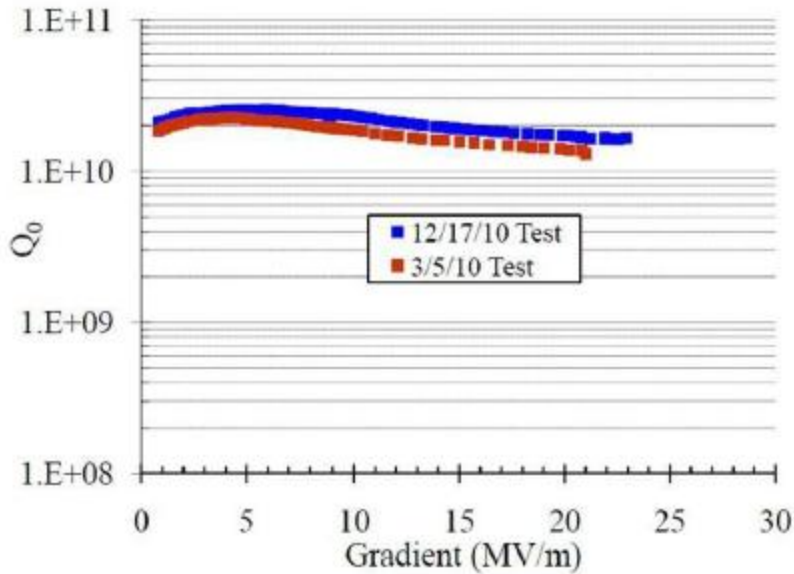

Figure 8: Quality factor  $Q_0$  as a function of accelerating gradient at 2 K, on the second 1.3 GHz single cell cavity.



**TE1CAT003 with RRCAT-IUAC & FNAL team members**



# 650 MHz FNAL progress



- Preliminary 1-cell design for both betas was presented at LINAC10 (MOP099 by S. Barbanotti et al.)
- 5-cell  $\beta=0.9$  cavity design nearly final

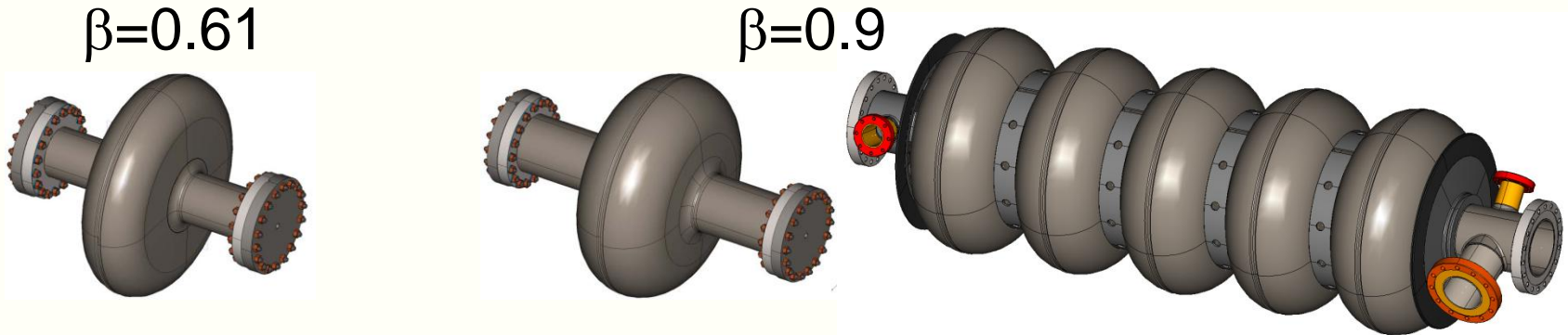

- Cavity fabrication
  - Ordered six prototype  $\beta=0.9$  1-cells from industry (AES), first two expected July 2011
  - Will order 2 prototype  $\beta=0.9$  5-cells soon
- Cavity infrastructure development for process and test in progress



# 650 MHz IIFC Progress

- 650 MHz  $\beta=0.9$  1-cell and 5-cell cavities to be built, based on experienced gained from 1.3 GHz work at RRCAT and IUAC.



Die- Punch Set at RRCAT



Aluminum blank, 3mm thickness



Die-Punch Set mounted on Press at RRCAT



Beginning of forming trials with aluminum





# 650 MHz IIFC Progress

- Simulations of 650 MHz  $\beta=0.61$  5-cell cavity at VECC
  - Design comparison using FNAL design input: 2D-SLANS [FNAL], 3D-HFSS [VECC], 3D-CST [VECC], 2D-SUPERFISH [VECC]
  - Some modifications to FNAL design also simulated in 3D-HFSS
  - Fruitful interactions of VECC staff with Fermilab and JLab RF designers have occurred

## CST MWS simulation for elliptical SCRF cavity at VECC

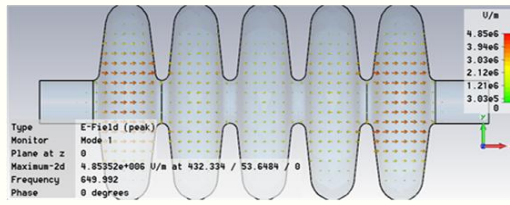

Electric field lines inside the cavity

Frequency : 650 MHz  
 $\beta : 0.61$

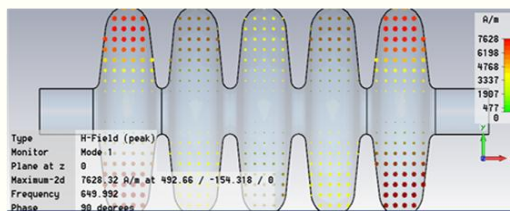

Magnetic field lines inside the cavity

### Latest Design Results

Half-cell Length =  $L/2$  = 70.335 mm.  
Iris radius =  $R_{iris}$  = 48 mm.  
Equator radius =  $D/2$  = 197.4 mm.  
Equator ellipse ratio =  $A/B$  = 54 mm./ 58 mm.  
Iris ellipse ratio =  $a/b$  = 13.68 mm./30.82 mm.  
= 10.67/24.02 (for end-cell)  
Wall angle =  $\alpha$  = 2.4 deg. (mid-cell)  
= 4.5 deg. (end-cell)  
Ep/Eacc = 3.00  
Bp/Eacc = 4.84  
Eacc = 17 MV/m  
Stored Energy (U) = 118 Joule  
R/Q = 296  $\Omega$

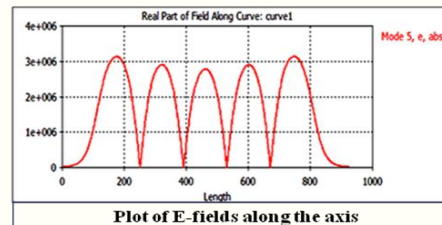



# End Group Development (RRCAT)



**Development of prototype in Low RRR Nb completed at Workshop, RRCAT.**

## Concept

- Machine out entire end group from a single billet of Nb. Billet is cheaper.
- Material from bore used for making HOM coupler and Form teil.

## Advantages

1. Easy manufacturing, Less Fabrication time.
2. Just 6 EB weld Joints instead of 13.
3. Pre Weld Etching reduced.
4. No pull out operations.
5. Machining operations. Better control on tolerances.
6. Rejections go down. Error in later welding stages causes complete rejection of job.
7. **LOWER COST: \$16500 per end group \$27000. (Machining costs in India)**

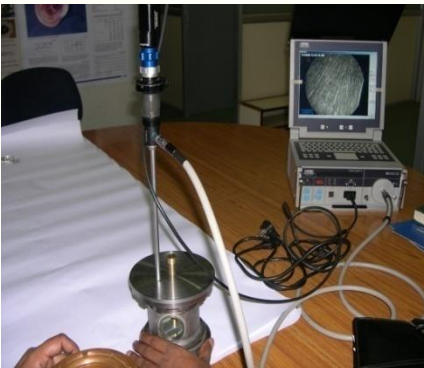

**Baroscopic examination**



**High RRR end group Machining in progress**

# Spoke Resonator Cryomodule

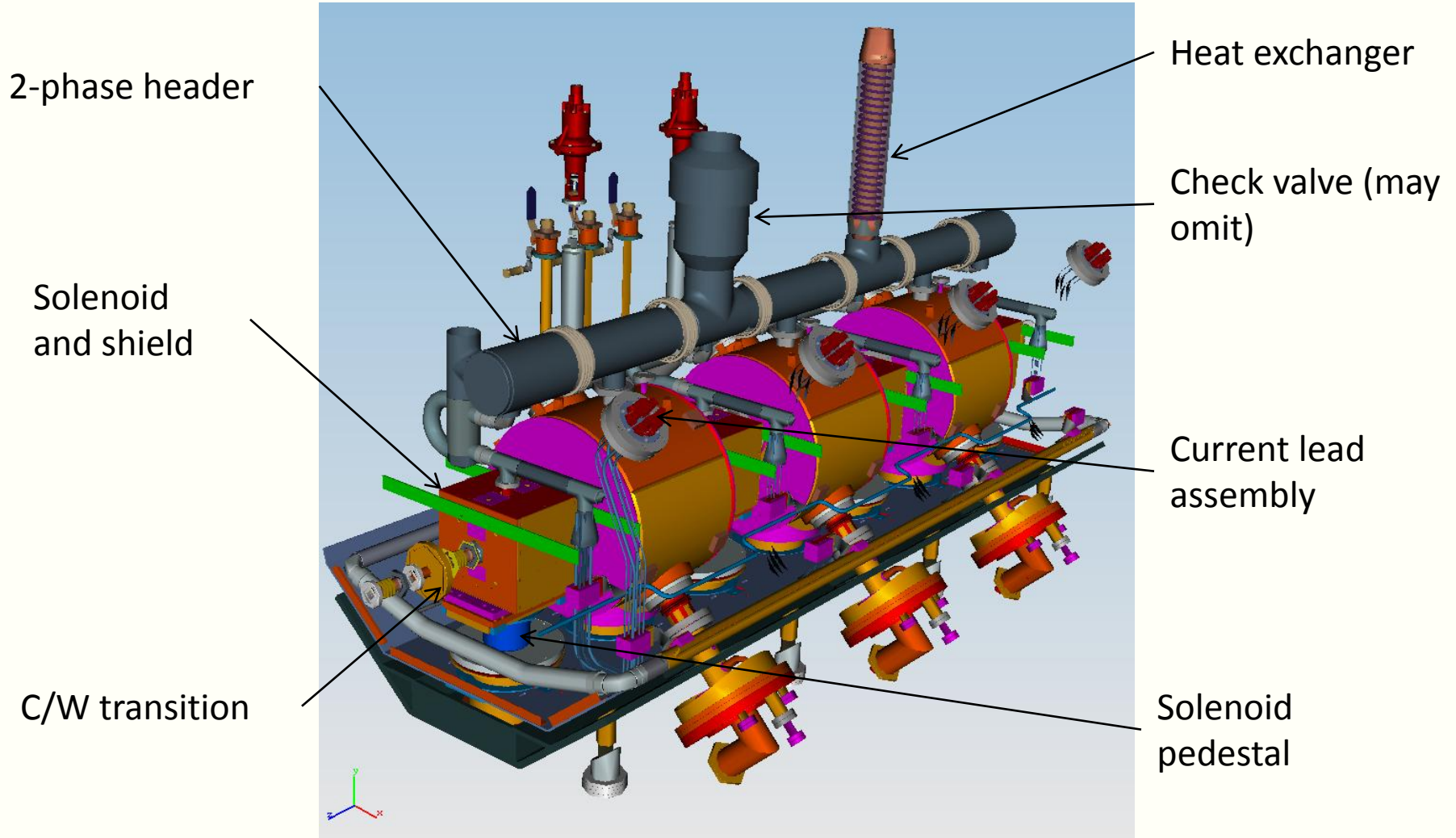



Fermilab

# Prototype SSR cryomodule

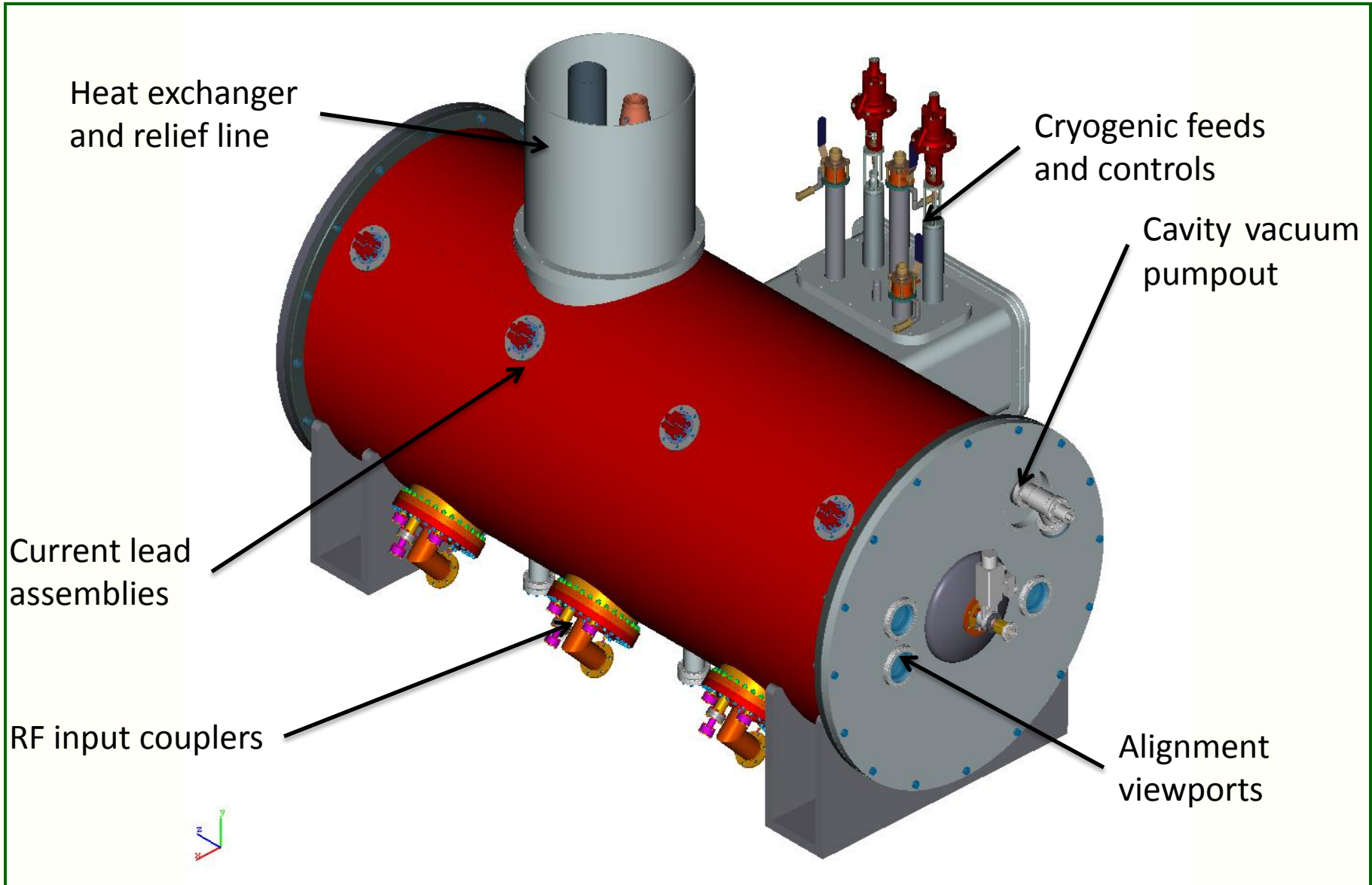



# Development of Cryomodule

## Initiated 650 MHz Cryomodule ( CW type)

- **650 MHz cryomodule team**
  - Design Effort is spearheaded by Tom Peterson (Sub Proj.Manager FNAL)
  - Prashant Khare, (with 4 engineers from RRCAT) is leading Indian effort . (Acts as point of contact for Indian Institutions)
  - Yuriy Orlov (Fermilab point of contact)
- **Design status**
  - Completed Cross Cultural study of designs prevalent at other accelerator laboratories (Jointly by RRCAT and Fermilab)
  - Finalized the Overall mechanical and thermal design. A closed-ended cryomodule similar to TESLA-Type selected as an initial baseline .  
Despite Choosing the Tesla Type as a baseline
    - Designs differ due to various kinds of requirements as this will be a CW cryomodule
    - Generally means adapting but not copying design concepts for Project X
  - Completed the design of Vacuum vessel, Thermal Shields and concurrent prototyping of cavity support system is in progress.
  - Value engineering of entire cryomodule forms a significant part of the effort.



Fermilab

# The Approach

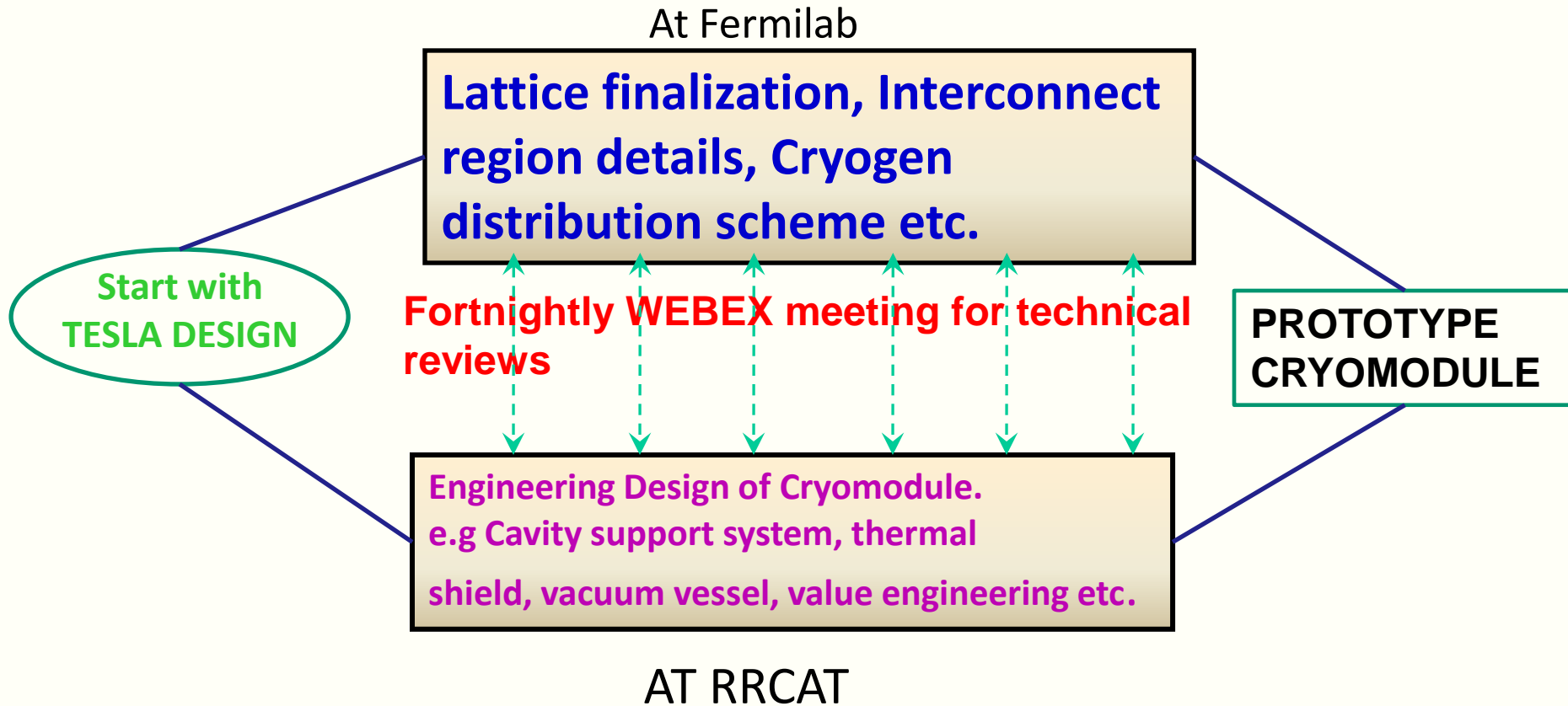

**Unique Features:-** As compared to conventional Tesla type Cryomodule.

- ❖ 650 MHz Cryomodule has a heat load of 25 W/cavity as it operates in CW mode. Earlier it was 0.9 W/cavity.
- ❖ The size of the cavity is almost two times i.e. 400mm dia.



# Design Status



- **Various cryomodule designs from laboratories around the world have been reviewed by Fermilab and RRCAT to understand “the state of the art” and to supplement our design concepts**
  - Designs differ due to various kinds of requirements
  - Generally means adapting but not copying design concepts for Project X
- **Overall mechanical and thermal design based on a closed-ended TESLA-style cryomodule has been selected as an initial baseline**
  - Design incorporates unique features for high dynamic heat loads at 2 K (~25 W/cavity)
  - CW operation and RF power tightly constrain cavity tune and microphonics



Fermilab

# 650 MHz Cryomodule



(Tesla Style-Stand Alone Concept Fermilab)

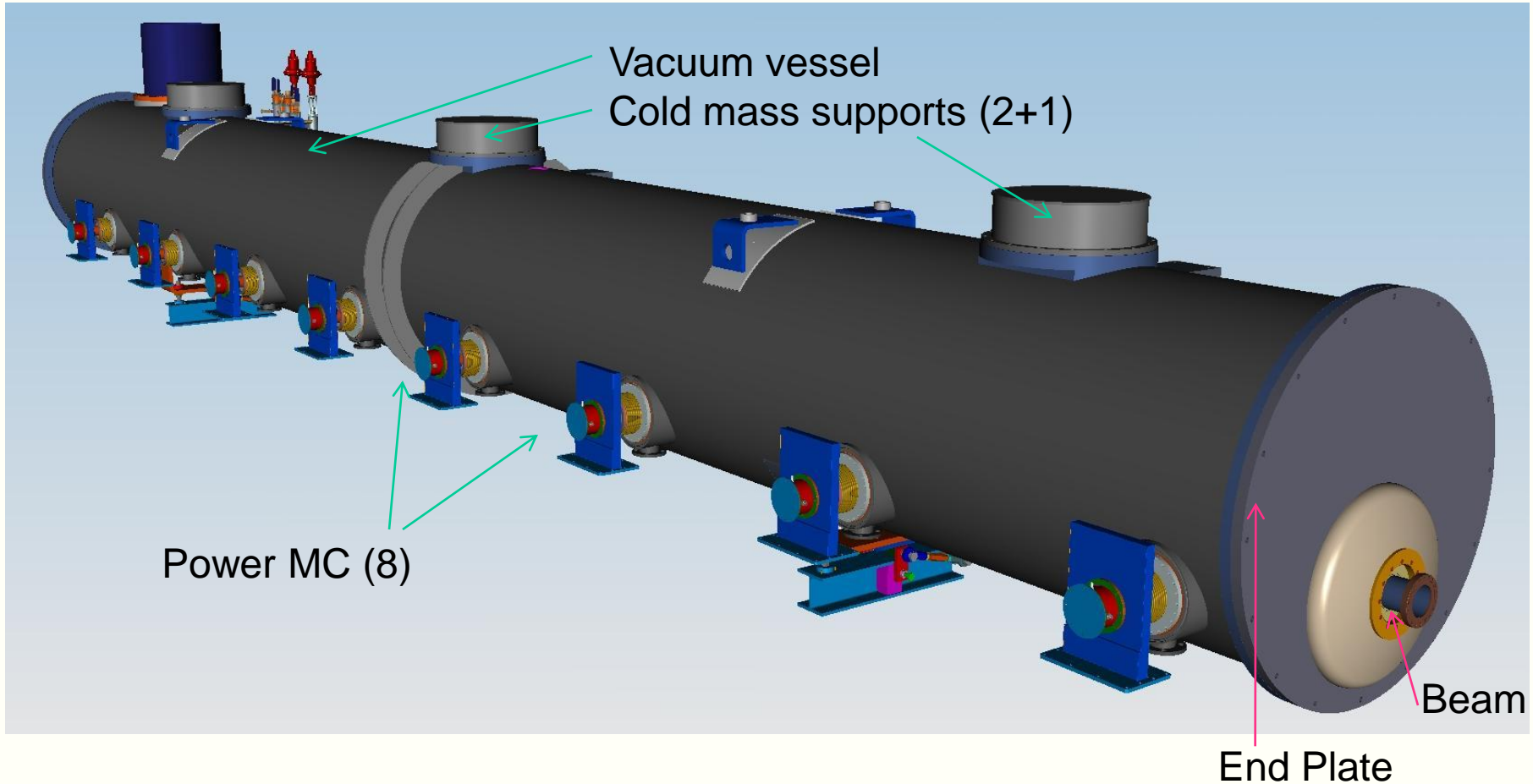





Fermilab

# 650 MHz Cryomodule



## Tesla Style Concept Cross-section Fermilab

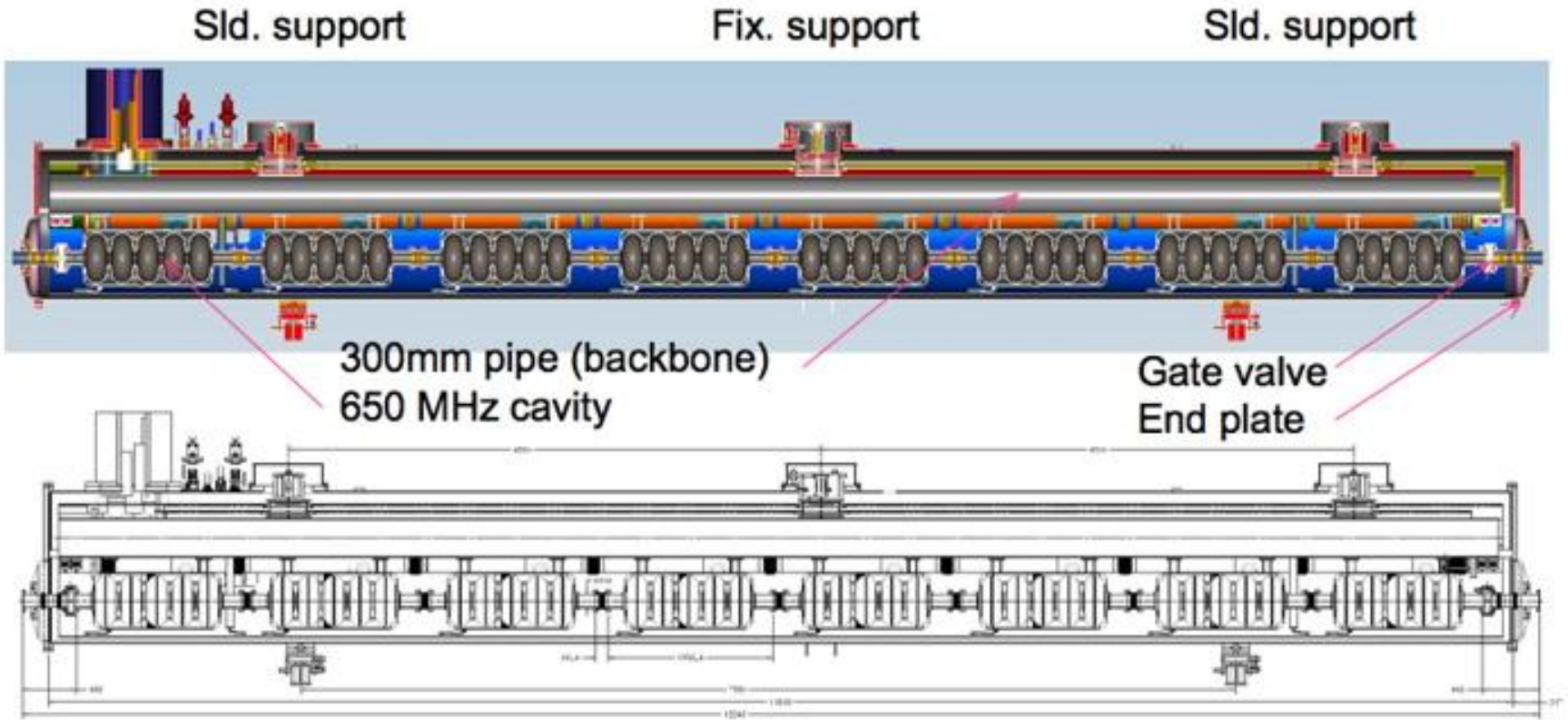

RRCAT

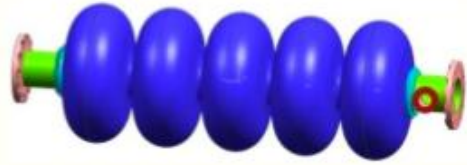

650 MHz SCRF CAVITY-UNDER  
FABRICATION AT RRCAT



He VESSEL to be fabricated

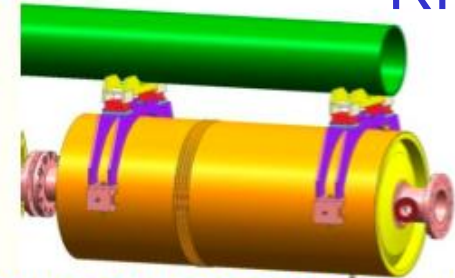

CAVITY SUPPORT SYSTEM UNDER  
PROTOTYPING AT RRCAT

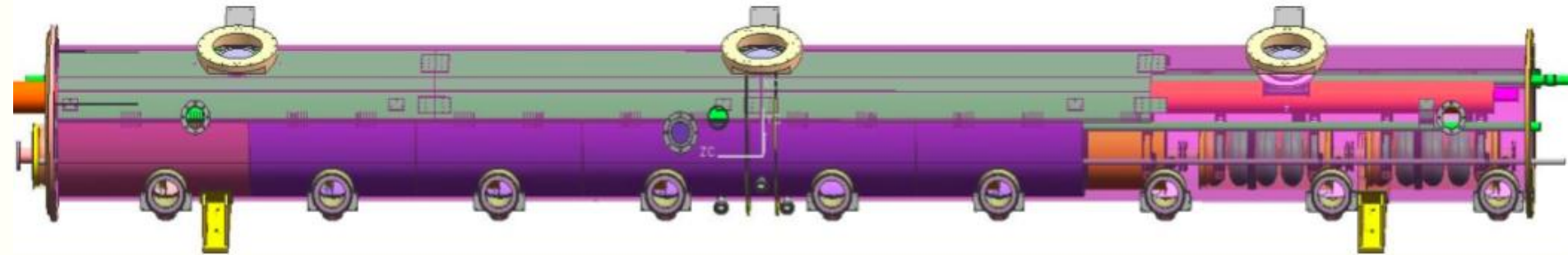

VACUUM VESSEL FOR CRYOMODULE  
UNDER DESIGNING AT RRCAT

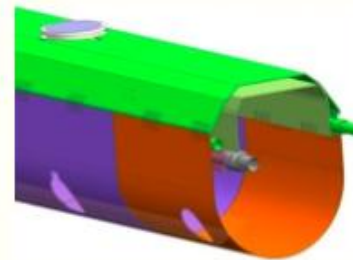

THERMAL SHIELD UNDER  
DESIGNING AT RRCAT

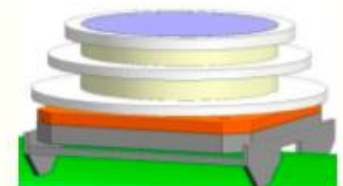

CRYOGENIC SUPPORT  
POST UNDER  
PROTOTYPING AT RRCAT

# Glimpses of 650 MHz CM 3-D Model (more from RRCAT contd...)

## SCRF Cavity supported on HGR pipe

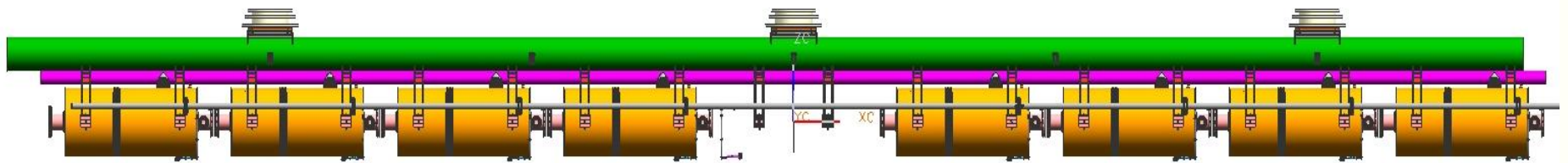

- The model incorporates a modified Cavity support system.
- 2K helium supply line includes a bellow in vertical configuration



# Steady State & Transient Thermal Analysis

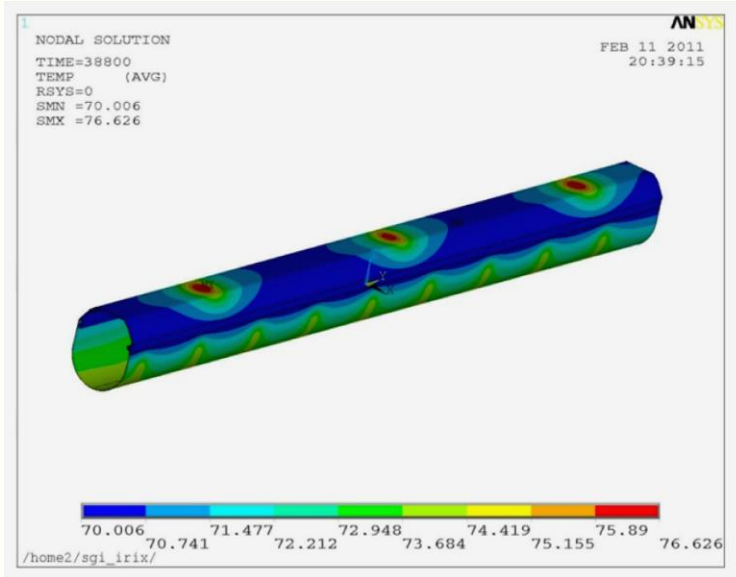

1. Mass flow rate- 24 gm/sec
2. Convection heat transfer coefficient- 200 W/m<sup>2</sup>K
3. Heat load:  
Through support post: 10 watt per support post  
Through coupler input: 2 watt per coupler input

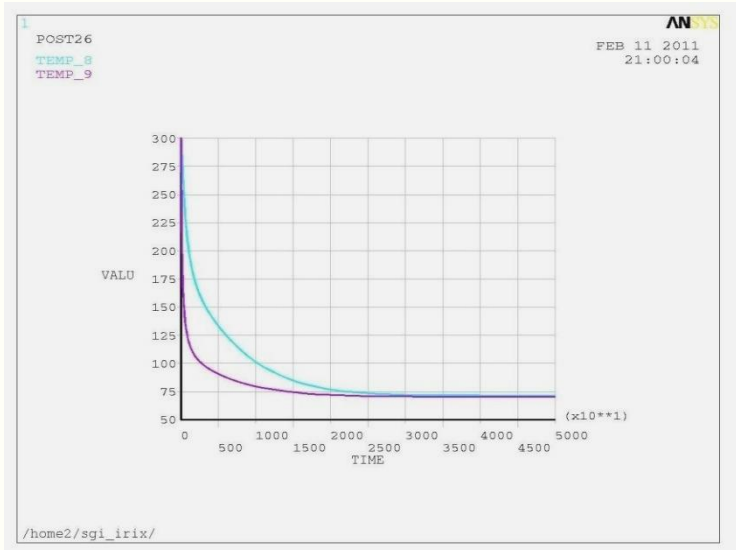

- A. Cool down reached in 10.7 Hour
- B. Max temperature gradient is found to be less than 40 K at finger weld region
- C. Fig. shows the temperature plot of 70 K thermal shield after 10.7 hours



# Snippets of Prototyping & Testing

Fermilab

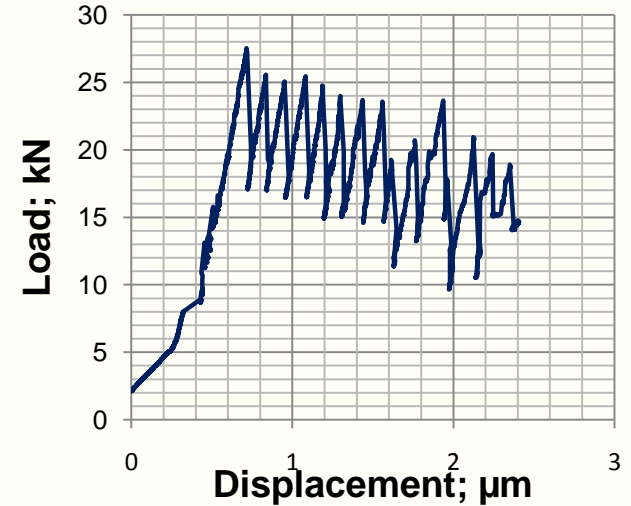

Cryogenic Support Post

Load Testing of Cryogenic Support Post prototype at RRCAT



Laser welding of Cavity Support system at RRCAT

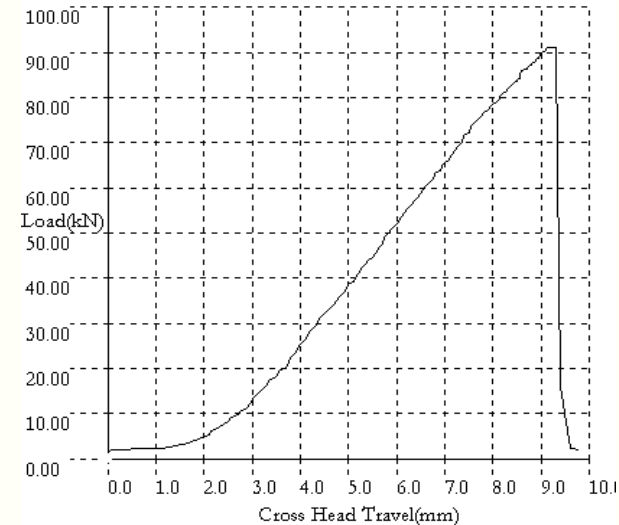

Load Testing of Cavity Support System

# All calculations done on Spreadsheet ( to Facilitate Any Change)



## Calculate Thickness required for G11 tube

**Dimension in red can be changed for variation of inputs**

OD of G11 Tube	60 mm				
Factor A =	109180	Factor B =	5199.06		
Factor A = $\frac{4F_g L}{\pi d}$		Factor B = $\frac{W}{\pi d}$			
<b>Thickness Req</b>	<b>1.5</b> mm	Considering Bending and Direct Compression			
Factor C =	4.5E-11	Factor D =	6550.82	Factor E =	311.944
Factor C = $\frac{1.5\sqrt{3}\sqrt{1-\mu^2}}{2E}$		Factor D = $\frac{4F_g L}{\pi d}$		Factor E = $\frac{W}{\pi}$	
<b>Thickness req</b>	<b>0.53</b> mm	Considering Elastic Instability			

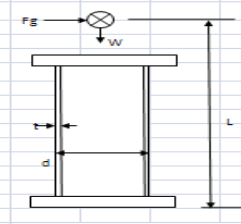

At the base of tube  
Tensile stress due to bending and direct compression  $\sigma = \frac{F_g L d}{2I} - \frac{W}{A}$

Simplifying  $t = \frac{1}{\sigma} \left[ \frac{4F_g L}{\pi d^2} - \frac{W}{\pi d} \right]$  **All units are in SI**

**Next to check for elastic instability**  $\frac{2Et}{1.5\sqrt{3}\sqrt{1-\mu^2}d}$

Simplifying  $t^2 = \frac{1.5\sqrt{3}\sqrt{1-\mu^2}}{2E} \left[ \frac{4F_g L}{\pi d} - \frac{W}{\pi} \right]$

**Ref: SSC Magnet Cryostat Suspension System Design Advances in Cryogenic Engineering Vol 33, p227**

Cross section area of G11 tube,  $A = \pi r^2 d$   
Moment of Inertia,  $I = \pi r^4 t = (\pi/8)d^4 t$   
Where OD of tube  $d = 2r$

$F_g$  is lateral component of shipping, handling and seismic load  
 $W$  is load per support post  
 $L$  is the distance of C.G. of cold mass from base of support post

## Calculate Contact Pressure of the Joint and Maximum Axial Load Limit

ID of SS Disc, d1	38.1 mm	Poisson's Ratio SS304 Disc	$\mu_1 =$	0.3	Young's Modulus SS304 Disc, E1 =	200 Gpa =	200000 N/mm2
ID of G11 Tube, d2 =	86.1 mm	Poisson's Ratio G11 Tube	$\mu_2 =$	0.2	Young's Modulus G11 Tube, E2 =	28 Gpa =	28000 N/mm2
OD of G11 Tube, d3 =	88.9 mm	Poisson's Ratio SS304 Ring	$\mu_3 =$	0.3	Young's Modulus SS304 Ring, E3 =	200 Gpa =	200000 N/mm2
OD of SS Disc, d4	114.3 mm						
Diametral Interference between Disc and Tube, $\delta_1$	0.457 mm						
Diametral Clearance between Disc and Tube, $\delta_0$	0.323 mm						
Thickness of SS304 Disc/Ring, h	19 mm						
FrictionCoeff SS304 Disc and G11 Tube, f1	0.3						
FrictionCoeff SS304 Ring and G11 Tube, f2	0.3						
K1 =	0.00051	K2 =	0.09673	K3 =	0.09919		
K4 =	0.09861	K5 =	0.00194	K6 =	0.09607		
$P_0 =$	50.31 N/mm2						
$P_1 =$	56.02 N/mm2						
$F_0 =$	80091.3 N	$=$	8172.58 Kg				
$F_1 =$	86369.1 N	$=$	8813.17 Kg				

**From 293K to 10** (Source: cryogenics.nist.gov)  
 $\Delta L/L$  Al 6061T6 3.7 mm/m  
 $\Delta L/L$  G10 Tube (Warp) 2 mm/m  
 $\Delta L/L$  Al SS304 2.6 mm/m

$$P_i = \frac{P_0(K_4 + K_5) + \delta_0}{K_6}$$

$$P_o = \frac{\delta_1 K_6 - \delta_0(K_4 + K_5)}{(K_4 + K_5)(K_1 + K_2) - K_6 K_3}$$

$P_i$  is inner contact pressure between disc and tube  
 $P_o$  is outer contact pressure between tube and ring

$$K_1 = \frac{P_1 d_1}{\pi h} \left[ \frac{d_1}{d_2} \frac{1}{1 + \mu_1} + \frac{d_1}{d_2} \frac{1}{1 - \mu_1} - \mu_1 \right]$$

$$K_2 = \frac{P_1 d_1}{\pi h} \left[ \frac{d_1}{d_2} \frac{1}{1 + \mu_2} + \frac{d_1}{d_2} \frac{1}{1 - \mu_2} - \mu_2 \right]$$

$$K_3 = \frac{P_1 d_1}{\pi h} \left[ \frac{d_1}{d_3} \frac{1}{1 + \mu_3} + \frac{d_1}{d_3} \frac{1}{1 - \mu_3} - \mu_3 \right]$$

$$K_4 = \frac{P_1 d_1}{\pi h} \left[ \frac{d_1}{d_4} \frac{1}{1 + \mu_1} + \frac{d_1}{d_4} \frac{1}{1 - \mu_1} - \mu_1 \right]$$

$$K_5 = \frac{P_1 d_1}{\pi h} \left[ \frac{d_1}{d_3} \frac{1}{1 + \mu_3} + \frac{d_1}{d_3} \frac{1}{1 - \mu_3} - \mu_3 \right]$$

$$K_6 = \frac{P_1 d_1}{\pi h} \left[ \frac{d_1}{d_4} \frac{1}{1 + \mu_1} + \frac{d_1}{d_4} \frac{1}{1 - \mu_1} - \mu_1 \right]$$

$$F_0 = f_1 \pi d_3 h P_0$$

$$F_1 = f_2 \pi d_2 h P_1$$

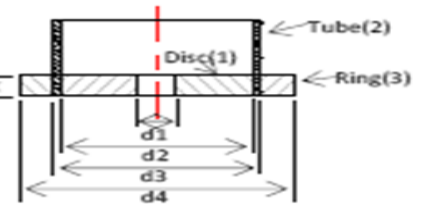

## Now Check whether Recommended Interference between G11 tube and SS304 Disc is Feasible for Assembly During Shrink Fitting

Min ID G11	Max Diametral Interference	Max OD SS304 before Shrink	SS shrinkage upto 80K	OD SS304 after Shrink	Effective Diametral Clearance for Assembly
mm	mm	mm	mm	mm	mm
86.1	0.457	86.557	0.225	86.332	-0.232

## Calculate Stresses in the Material of Disc, Tube and Ring

<b>Inner Disc SS304</b>			
$\sigma_{r,d1} =$	0 N/mm2	$\sigma_{r,d2} =$	-56.02 N/mm2
$\sigma_{c,d1} =$	-139.32 N/mm2	$\sigma_{c,d2} =$	-83.30 N/mm2
<b>Tube G11</b>			
$\sigma_{r,d2} =$	-56.02 N/mm2	$\sigma_{r,d3} =$	-50.31 N/mm2
$\sigma_{c,d2} =$	128.11 N/mm2	$\sigma_{c,d3} =$	122.40 N/mm2
<b>Outer Ring SS304</b>			
$\sigma_{r,d3} =$	-50.31 N/mm2	$\sigma_{r,d4} =$	0 N/mm2
$\sigma_{c,d3} =$	204.39 N/mm2	$\sigma_{c,d4} =$	154.08 N/mm2

$$\sigma_{e,d1 Disc} = 0$$

$$\sigma_{e,d1 Disc} = -\frac{2P_1 d_1^2}{d_2^2 - d_1^2}$$

$$\sigma_{e,d2 Disc} = -P_i$$

$$\sigma_{e,d2 Disc} = -\frac{P_i(d_2^2 + d_1^2)}{d_2^2 - d_1^2}$$

$$\sigma_{e,d2 G11} = -P_i$$

$$\sigma_{e,d2 G11} = \frac{P_i(d_3^2 + d_2^2) - 2P_o d_3^2}{d_3^2 - d_2^2}$$

$$\sigma_{e,d3 G11} = -P_o$$

$$\sigma_{e,d3 G11} = \frac{2P_1 d_1^2 - P_o(d_3^2 + d_2^2)}{d_3^2 - d_2^2}$$

$$\sigma_{e,d3 Ring} = -P_o$$

$$\sigma_{e,d3 Ring} = \frac{P_o(d_4^2 + d_3^2)}{d_4^2 - d_3^2}$$

$$\sigma_{e,d4 Ring} = 0$$

$$\sigma_{e,d4 Ring} = \frac{2P_o d_3^2}{d_4^2 - d_3^2}$$



Fermilab

# Remarks on Cryomodule Development



- Many very good ideas and much work have already gone into cryomodule design by various laboratories around the world .
- Fermilab and RRCAT are building upon the experience from these laboratories as well as continuing our own analysis & design work in developing a cryomodule design for the unique requirements of 650 MHz, CW section of the Project X linac.
- Tesla type of cryomodule has been taken as the baseline and this design is being modified to accommodate the requirements of the project .
- A major value engineering exercise has been taken up .
- Very close interaction through fortnightly WEBEX meetings has resulted in covering a lot of ground.



**VTS**

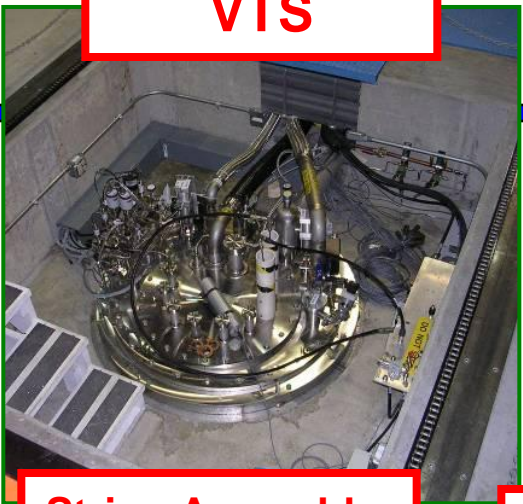

**ANL/FNAL EP**



**String Assembly**

**MP9 Clean Room**



**HTS**



**VTS**

**Final Assembly**



**1<sup>st</sup> U.S. built ILC/PX Cryomodule**



**1<sup>st</sup> Dressed Cavity**







Fermilab

# Fermilab Vertical Test Stand





# Vertical Test Stand Design



- Indian Institutions have provided engineering resources to design an upgraded Vertical Test Stand for Fermilab.
  - It is being fabricated by a US vendor using ARRA funds
  - RRCAT also purchased one

- RRCAT has carried out design of the following:

- Liquid Helium Vessel Shell
- Liquid Helium Vessel Top Flange
- Vacuum Vessel Shell
- Vacuum Vessel Flange
- Top Insert Plate

- RRCAT has also verified the design of following by Analysis

- Assembly of LHe Vessel Top Flange, Weld Rim
- Top Insert Plate
- Assembly of Vacuum Vessel Flange, LHe Vessel Flange, Top Plate, Support Pads
- Magnetic Shield design – 300K & 2K

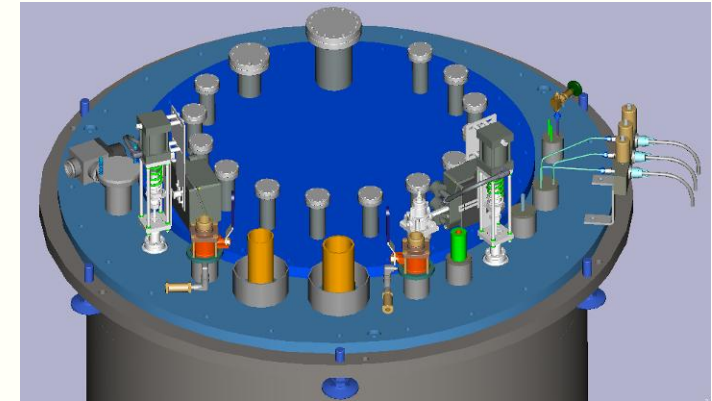

VTS-2 TOP PLATE – CRYOGENIC & VACUUM INSERTS

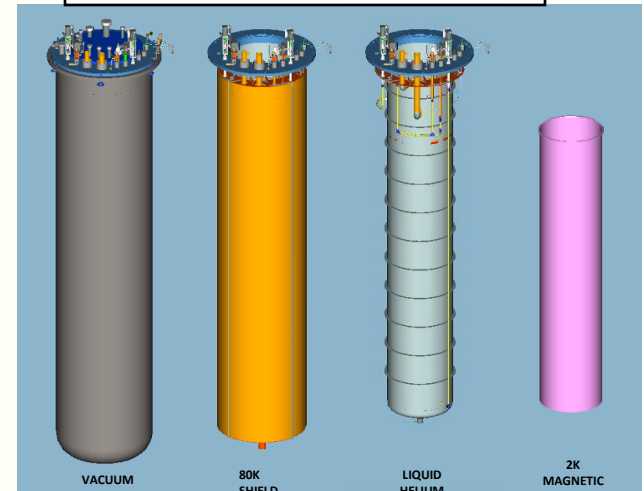

3-D MODELS OF VTS-2 VESSELS



Fermilab

# Horizontal Test Stand (HTS)

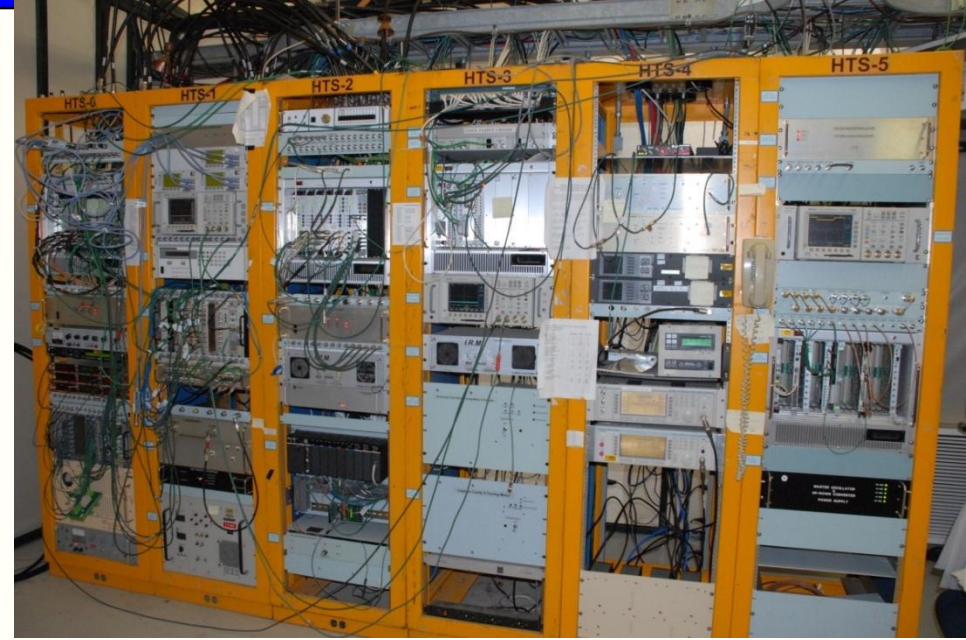

- **Purpose: high power tests of dressed cavities**
  - “high power” = tens to hundreds of kW of input power
  - “dressed” = LHe vessel, high power input coupler, mechanical tuners, HOM couplers
- **Test goal 1: qualify cavities for CM assembly based on  $Q_0$ ,  $E_{acc}$ , field emission**
- **Test goal 2: verify functionality of auxiliary components**



# HTS data: examples



TB9RI018, 2.0 K, 5 Hz

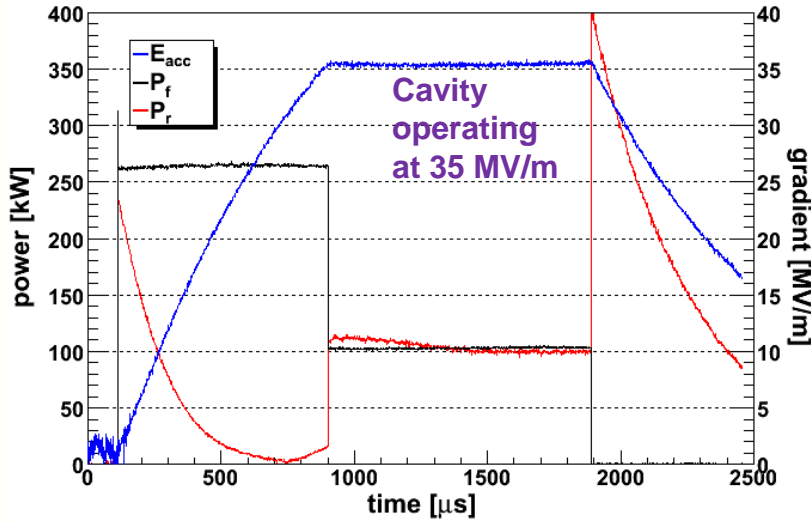

TB9RI018, 5 Hz, 2 K, 800+1000  $\mu$ s pulse

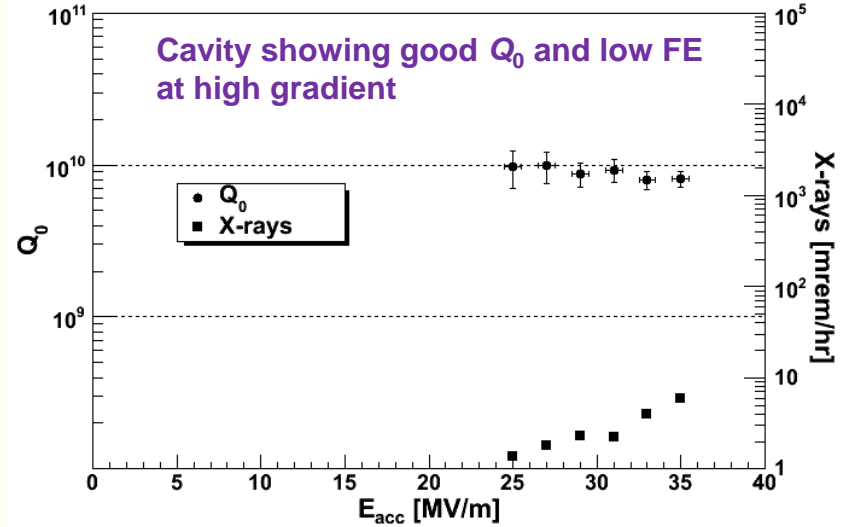

TB9RI018, 2 K, 5 Hz, 35 MV/m

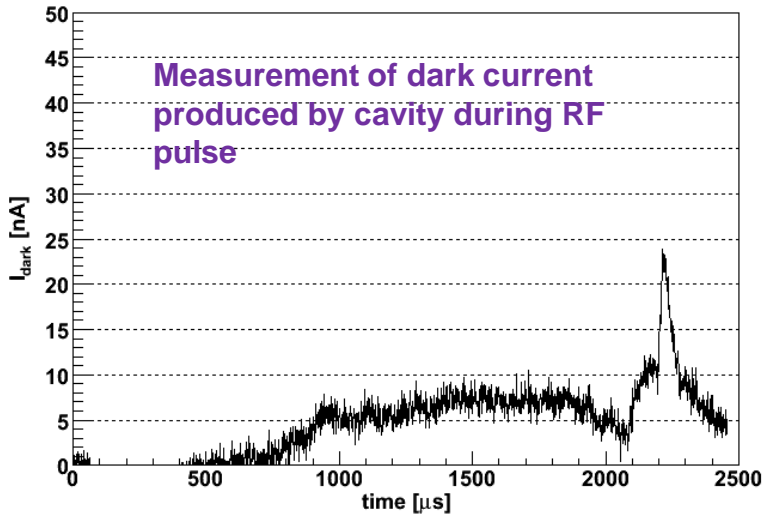

AES 007 slow tuner test

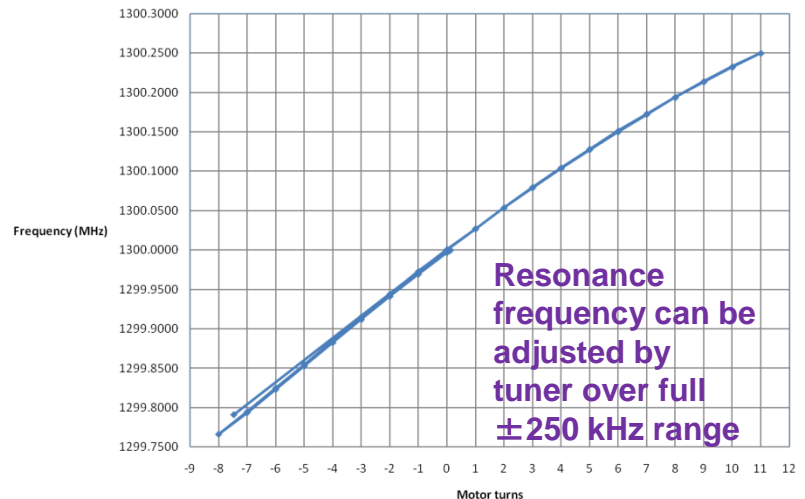



- **HTS-2 is a facility similar to HTS but with expanded capabilities**
  - **Cool down of two cavities simultaneously**
    - **Doubles the number of tests that can be done per thermal cycle**
  - **Testing of either 650 or 1300 MHz cavities**
  - **CW testing as well as pulsed**
  - **Testing a cavity + magnet package**
- **An IIFC project**
  - **India will design and procure the cryostat and its cryogenic feed box, including J-T heat exchanger**
  - **Fermilab will assemble RF system and other test infrastructure**
  - **Similar facility to be built in India based on HTS-2 experience**



Fermilab

# HTS-2 cryostat design at RRCAT

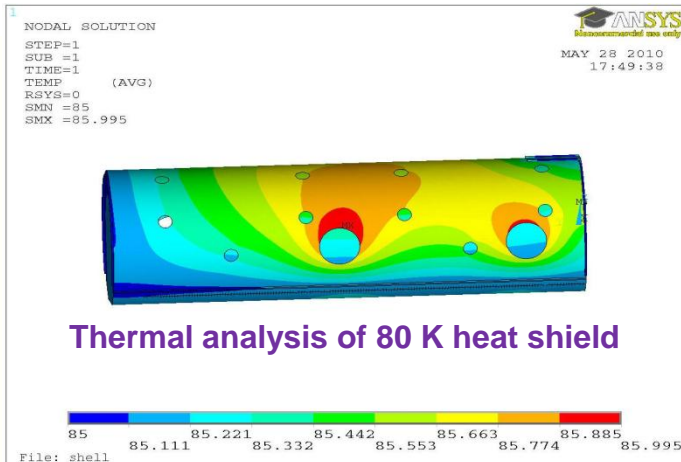
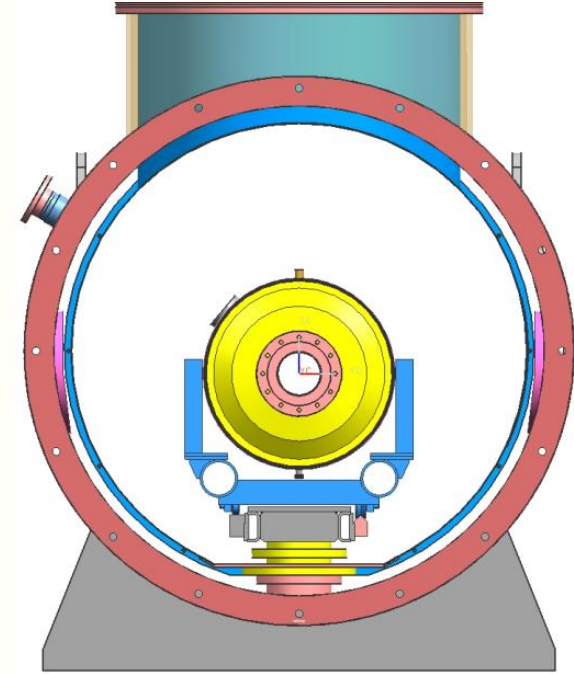
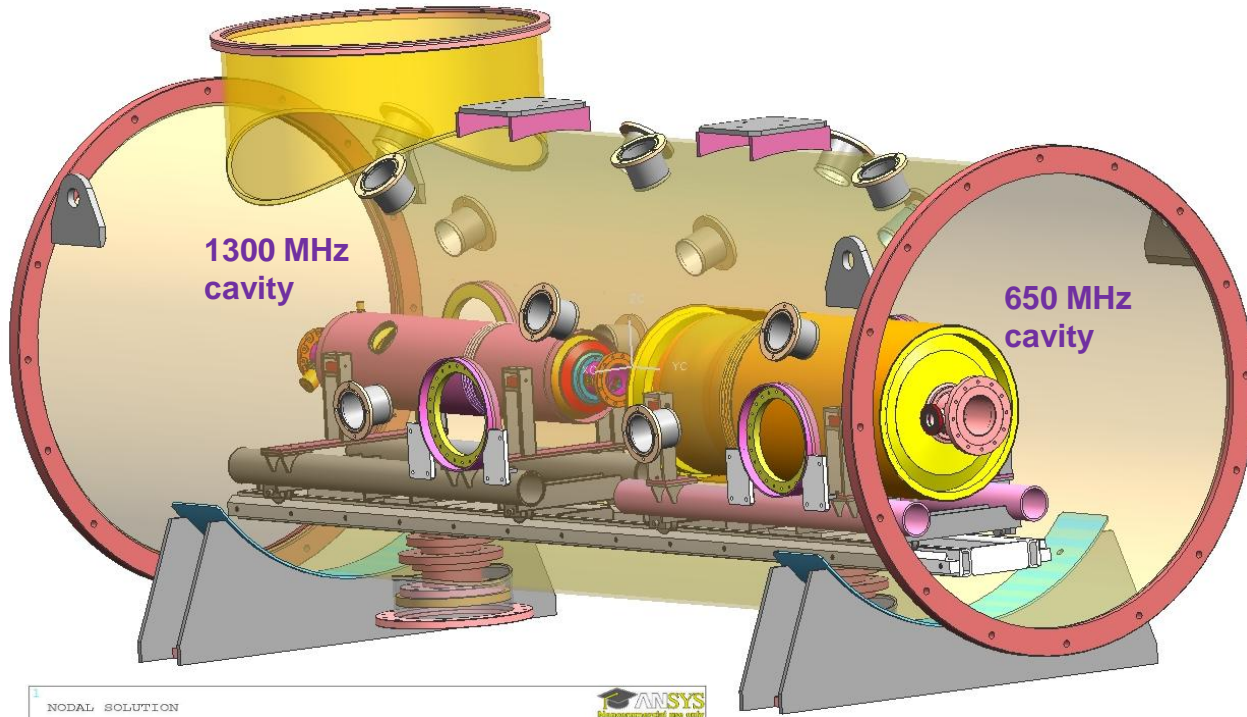

Preliminary cooling circuit design

HTS-2 COOLING CIRCUIT OPTION

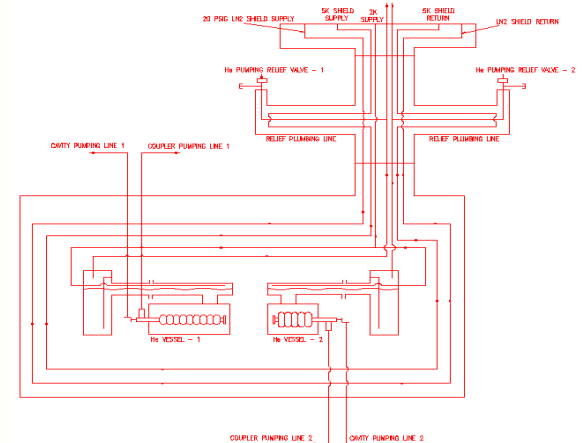



Fermilab

# 325 MHz Spoke Cavity Processing at ANL



- **Chemical polishing, high-pressure rinsing in G150 by Argonne and Fermilab SRF staff**
- **Cold testing performed at Fermilab**
- **Both cavities have achieved world leading performance**



Fermilab

# Cryomodule Assembly at Fermilab



- Extensive infrastructure completed for CM assembly



**String Assembly in Class 10  
area of MP9 Clean Room**



**Exterior of MP9 Clean Room**





Fermilab

# SRF Infrastructure at ANL



- Joint facility built by ANL/FNAL collaboration
- EP processing of 1300 MHz 9-cells
- Together with Jlab, ANL/FNAL facility represents state-of-the-art cavity processing facilities for ILC or Project X
- Adding 650 MHz processing infrastructure



**Electropolishing**



**Ultrasonic Cleaning**

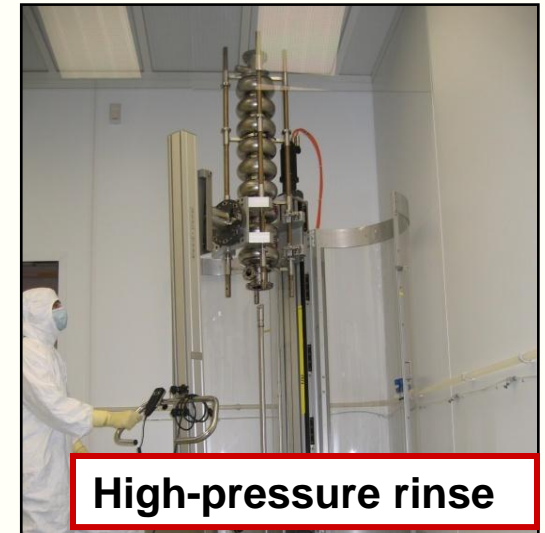

**High-pressure rinse**

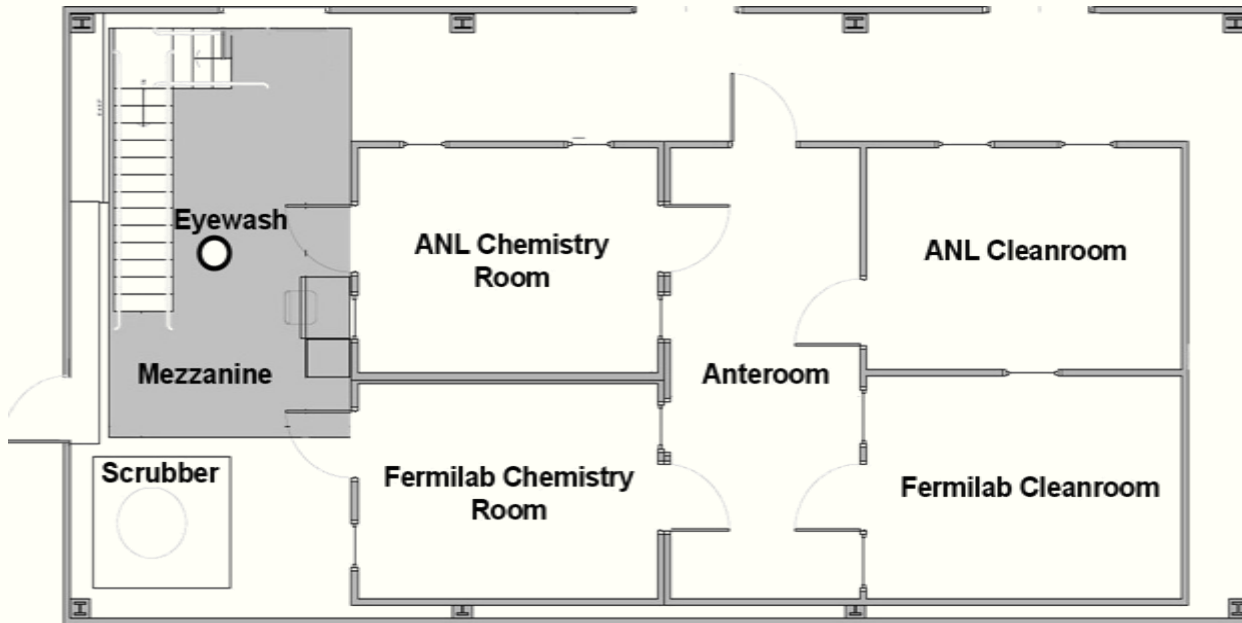



Fermilab

# SRF Infrastructure at Fermilab



- KEK/Kyoto optical inspection system, commissioned in 2009
- In routine use examining cavities after each step of processing

- Automated Cavity tuning machine
- DESY/FNAL/KEK collaboration
- 2 machines at DESY, one at KEK
- FNAL machine in routine use



**Optical Inspection Machine at ICB**

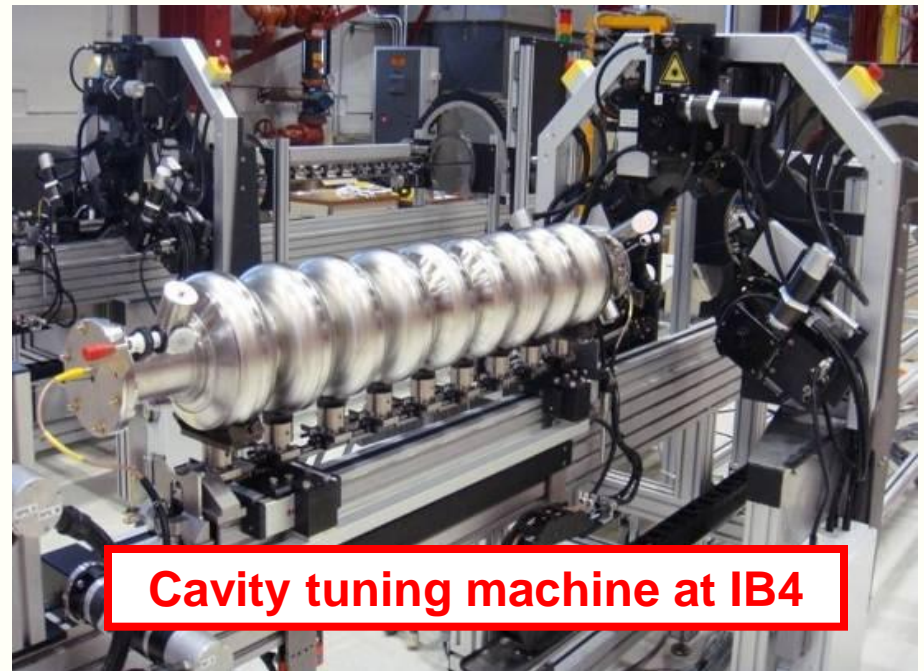

**Cavity tuning machine at IB4**



Fermilab

# SRF Infrastructure at Fermilab



**Vacuum Oven 1 of 2**

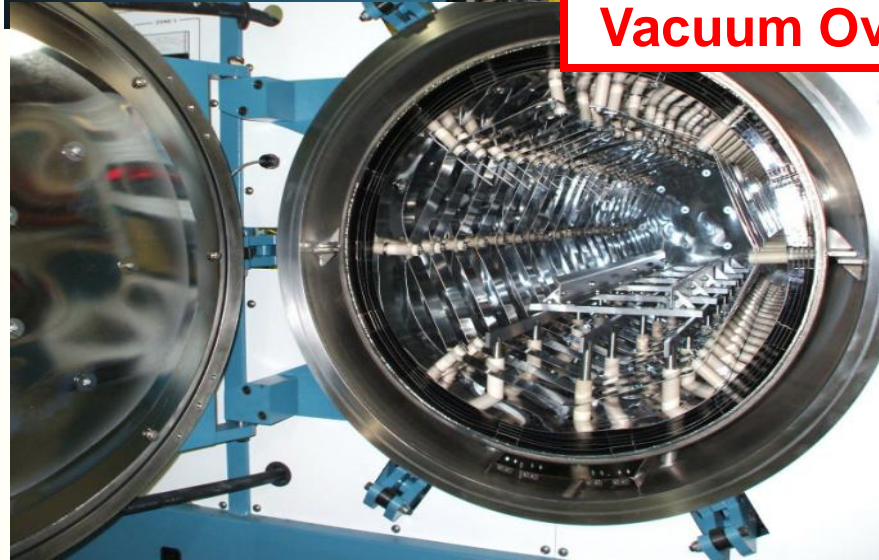

- Removes H<sub>2</sub> introduced during surface treatment
- Key to high Q operation at high gradient

Fermilab is helping RRCAT purchase this from US vendor

## Infrastructure installed at RRCAT in Collaboration with Fermilab

- Electro-polishing setup
- Centrifugal barrel polishing machine
- High pressure rinsing
- Cavity forming facility



Cavity forming facility

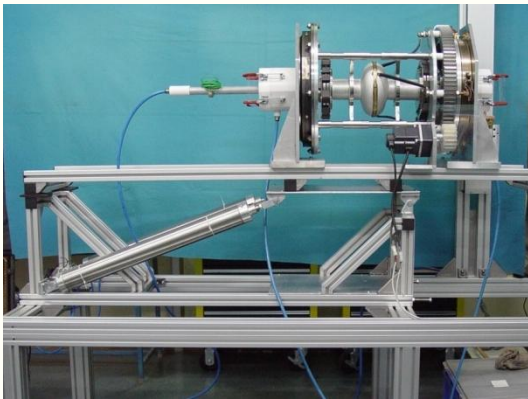

Electro-polishing setup



Centrifugal barrel polishing machine



High pressure rinsing Set up



Fermilab

# Infrastructural Work In Progress



Large scale SRF Infrastructure being set up at RRCAT in collaboration with Fermilab.

- Clean room (class 10000 to 10)
  - Fermilab Design
- Electron beam welding machine
  - US Vendor
- High vacuum annealing furnace
- Cavity machining facilities
- CMM, SIMS etc
- Building under construction (area 70m x 20m)



Building expected to be ready by mid  
- 2011



# SRF Test Linac Project Overview



- **Overall Goals**
  - **Build a RF Unit Test Facility at the New Muon Lab (NML)**
    - ILC RF Unit = 3 cryomodules
    - 10-MW RF system
    - Beam with ILC parameters (3.2 nC/bunch @3 MHz, Up to 3000 bunches @ 5Hz, 300- $\mu$ m rms bunch length)
  - **Build a RF Unit for Project X (like ILC but 4 cryomodules @25 MV/M)**
  - **Build Test facilities for Project-X cryomodules**
- **Phase-1 (FY07 – FY10) (Completed Dec. 2010)**
  - **Prepare facility for testing first cryomodule (CM1) without beam**
    - Infrastructure, RF power, cryogenics (Tevatron satellite refrigerators #1 & #2)
    - Install first cryomodule (CM1) and Capture Cavity-2 (CC2), cooldown, and begin RF testing
    - New tunnel civil construction (capability for 2 RF units)



# SRF Test Linac Project Overview



- **Phase-2 (FY11 – FY12)**
  - **Prepare for First Beam**
    - Civil construction for new cryoplant and test stands
    - Move parts from FNPL photo-injector to NML
    - Install new gun, injector, Test beamlines, and beam dump
    - Swap CM1 with second cryomodule (CM2) - (S1)
    - Commission gun – generate first beam
    - Accelerate beam through single cryomodule
  
- **Phase-3 (FY12 – FY14)**
  - **Complete RF Unit**
    - Upgrade RF system to 10 MW
    - Install RF Unit (3 cryomodules)
    - Commission new Cryogenic Plant
    - Operate full RF Unit with beam - (S2)







Fermilab

# Phase-1 Civil Construction



Funded by ARRA

Existing NML Building

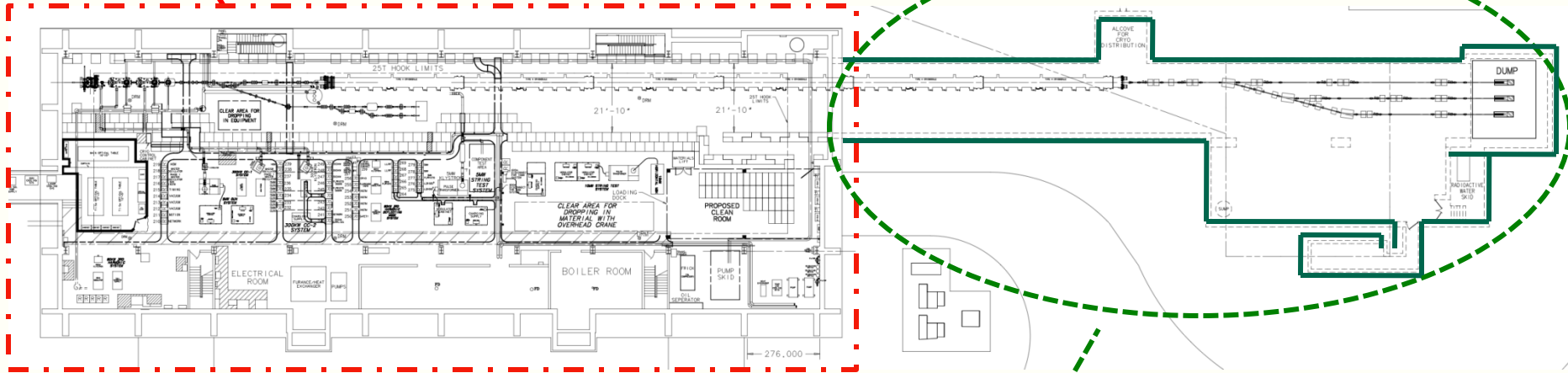

**New Underground Tunnel Expansion**

(Space for 6 Cryomodules (2 RF Units), AARD Test Beam Lines)



Fermilab



# Phase-2 Layout of SRF Test Linac

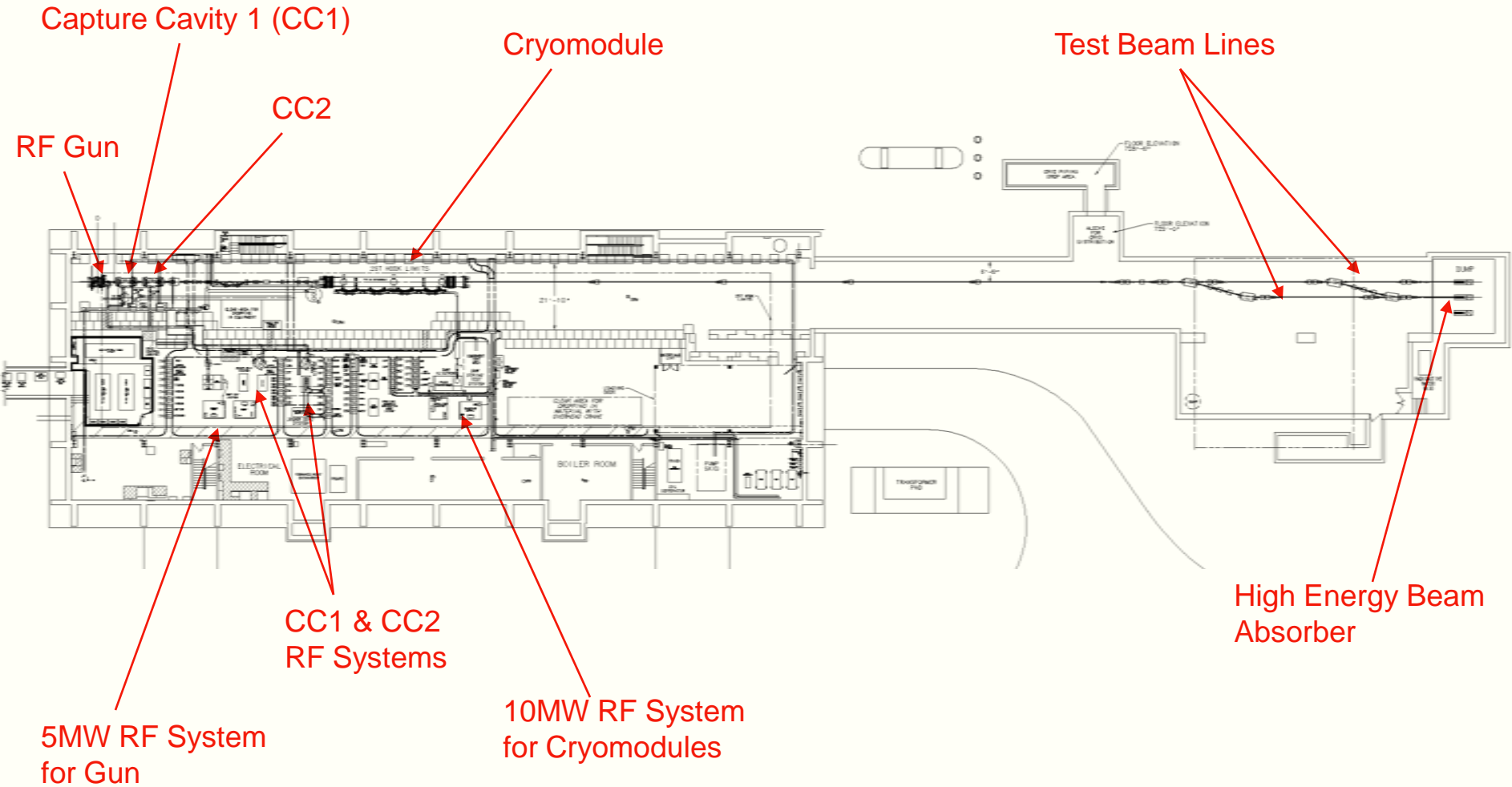



Fermilab

# Phase-2 Civil Construction



Vacuum Cleanroom

## New Cryoplant & CM Test Facility

(300 W Cryogenic Plant, Cryomodule Test Stands, RF Test Area, Vacuum Cleanroom)

Cryogenic Refrigerators

Compressor Building

RF Systems

Cryomodule Test Stands

Funded by ARRA

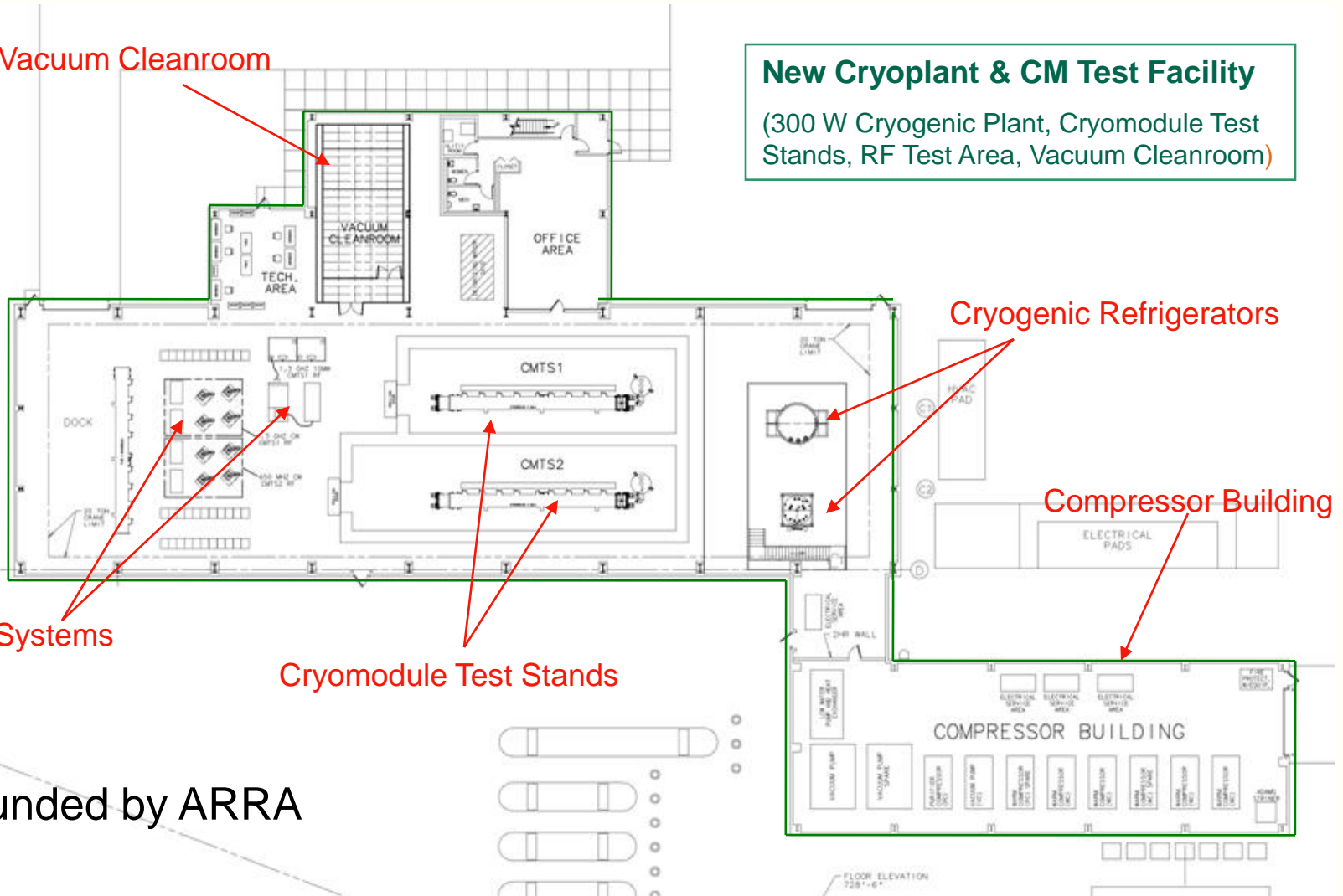



Fermilab

# Phase-3 of SRF Test Linac and CMTF



## New Cryoplant & CM Test Facility

(300 W Cryogenic Plant, Cryomodule Test Stands, RF Test Area, Vacuum Cleanroom)

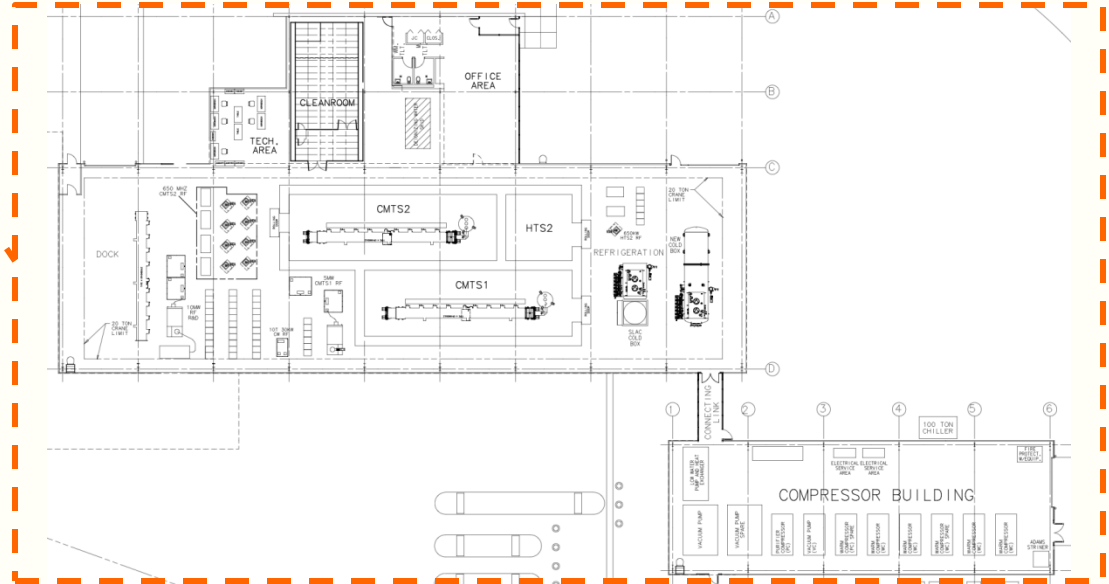

## Existing NML Building

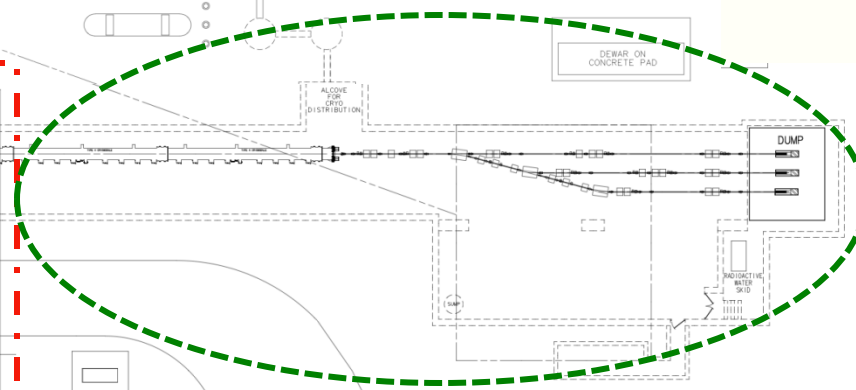
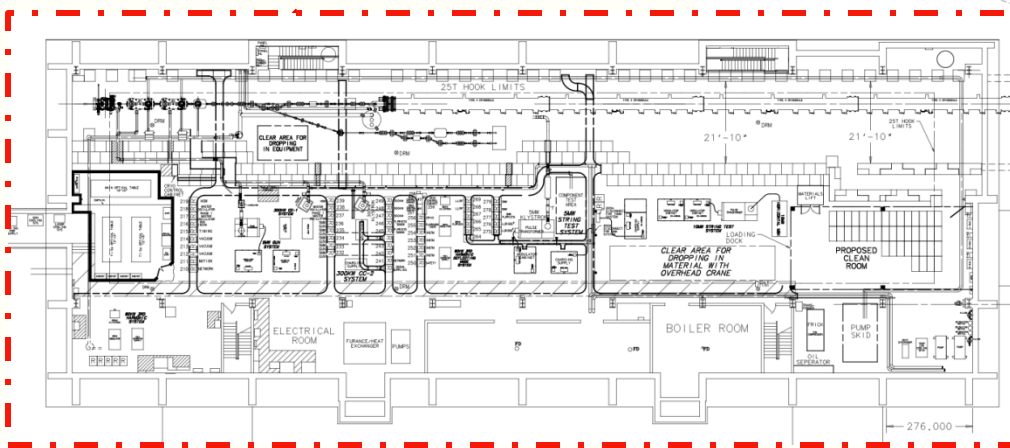

**New Underground Tunnel Expansion**  
(Space for 6 Cryomodules (2 RF Units), AARD Test Beam Lines)



Fermilab

# Future NML Complex





Fermilab

# Cryomodule-1 (CM1)





# Cool down of CM1

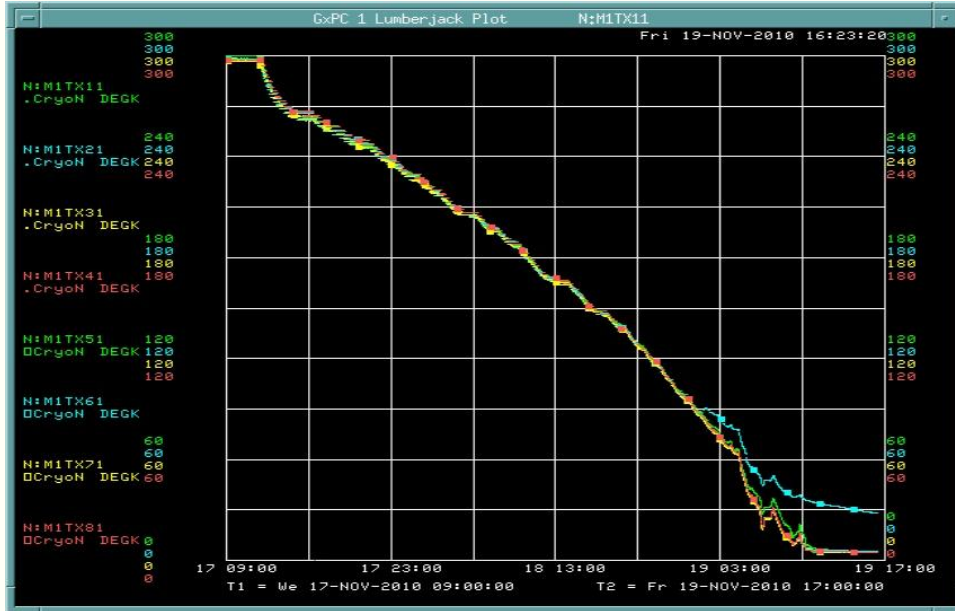

Cool down to 4.5 Kelvin  
(2+ days)

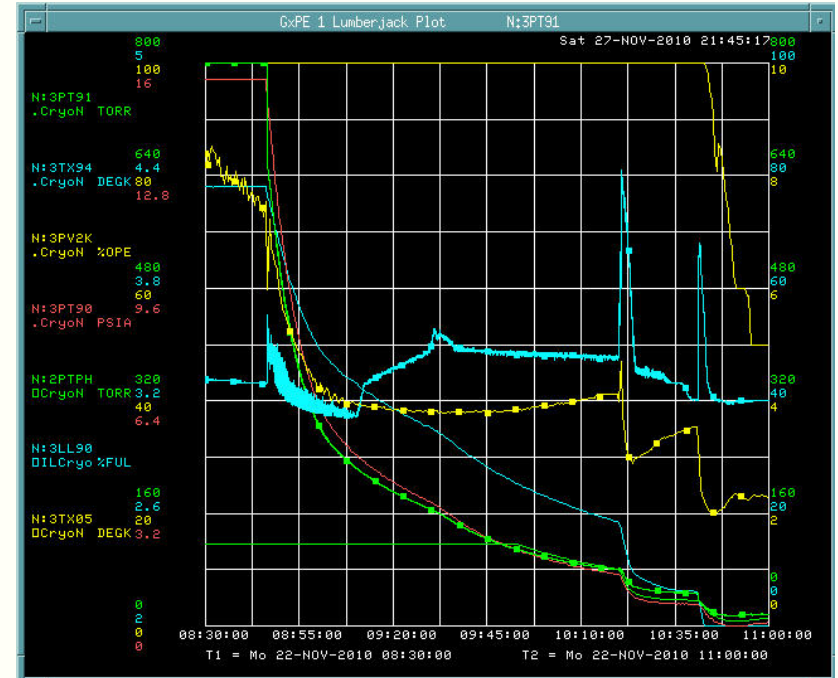

Cool down to 2 Kelvin  
(~2 hours)



Gradient (22 MV/m)

HOM temperature

Cavity vacuum

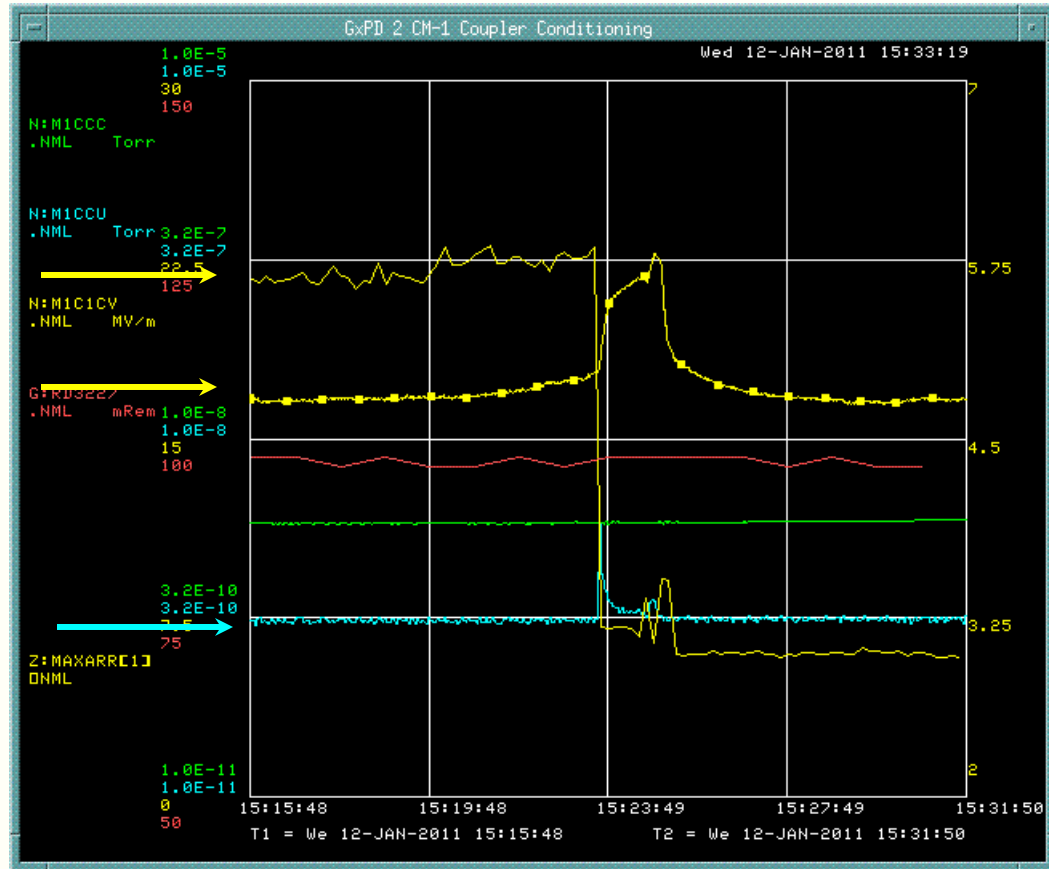

Fast Thermometry response during a possible quench





# BARC: Cryomodule Test Stand

- **Conceptual Arrangement of Feed Box, Feed Cap, End Cap & Transfer Lines.**

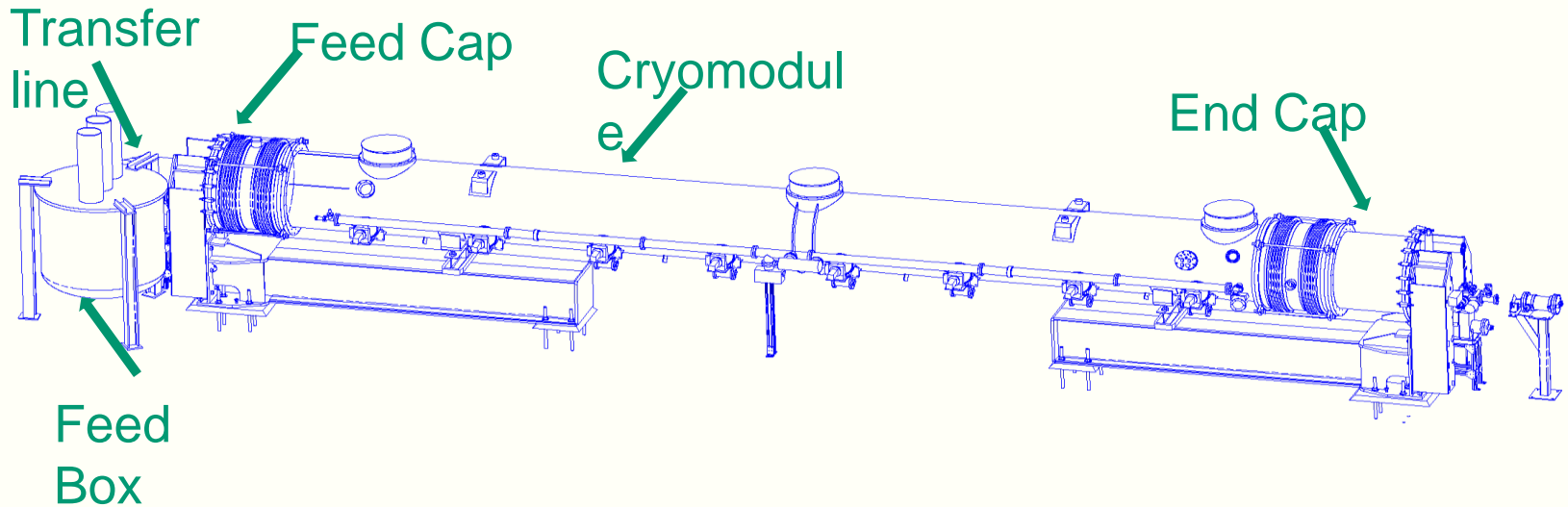

- **Status: Design & Drawing of all three sub-assemblies is taken up.**

- **CMTF (FY15): Test Stands for Project X**
  - Install shielding, RF, cryo for PX test stands
  - 1300 MHz (pulsed) CM test stand (with India)
  - 650 MHz (CW) CM test stand (with India)



Fermilab

# Accelerator Unit Test Status



- **Injector**
  - Detailed Lattice designed
  - New gun system being installed
    - Collaboration with DESY, KEK & INFN
  - CC2 (single 9-cell cavity) operational - 10/09
- **Accelerator**
  - CM1 installed, aligned, and under vacuum
  - Cooled, Under RF Power





# Phase II: R&D

- **The Phase II of this collaboration would expand the present R&D collaboration to all non SRF areas of Project-X**
- **Elements of Phase II: R&D**
  - **Front End: Source and RFQ**
  - **325 MHz RF Power**
  - **650 MHz RF Power**
  - **Power Coupler**
  - **Instrumentations and Controls**
  - **Superconducting Magnet**
  - **Cryogenics**
- **The technical discussions have already started**
  - **This meeting will outline these areas of collaboration**

- 1 kW ( 2 nos.) and 5 kW ( 1 No.) Solid-state amplifiers

## Specifications from Fermilab:

- Center frequency : 325 MHz
- Bandwidth (3 dB) : 10 MHz
- Power output (1 dB), CW : 1 kW and 5 kW
- Gain (1 dB), minimum : 50 dB
- Gain Stability : +/-0.5 dB
- Stability : Un conditionally Stable
- Cooling : Water Cooled
- Harmonics & Spurious : <30 dBc
- Efficiency (Total) : > 50%
- Gain Stabilization with in +/- 0.5 dB

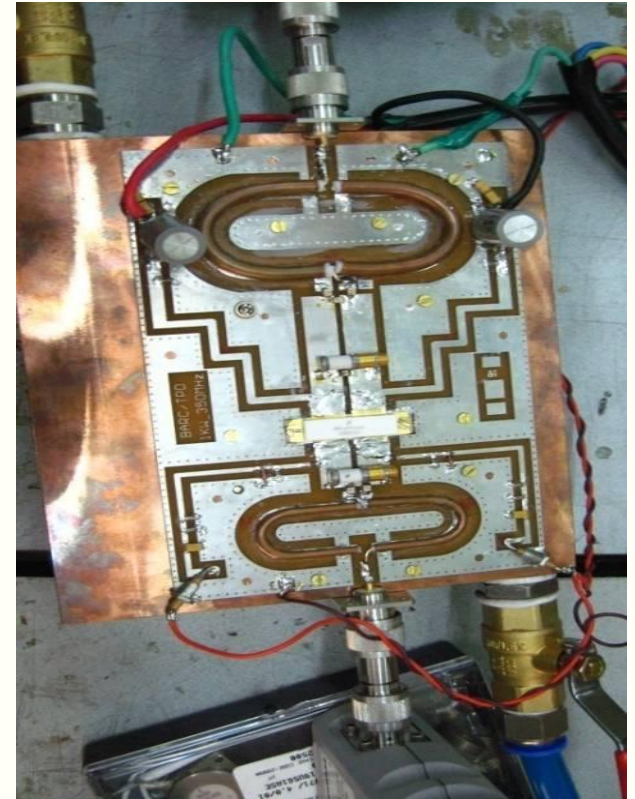

1 kW solid state module under testing at BARC



# Solid State Amplifier Development 650 MHz

- RRCAT has taken up development of 30 kW CW 650 MHz solid state amplifiers for energizing SCRF cavities

### 8kW Amplifier Scheme

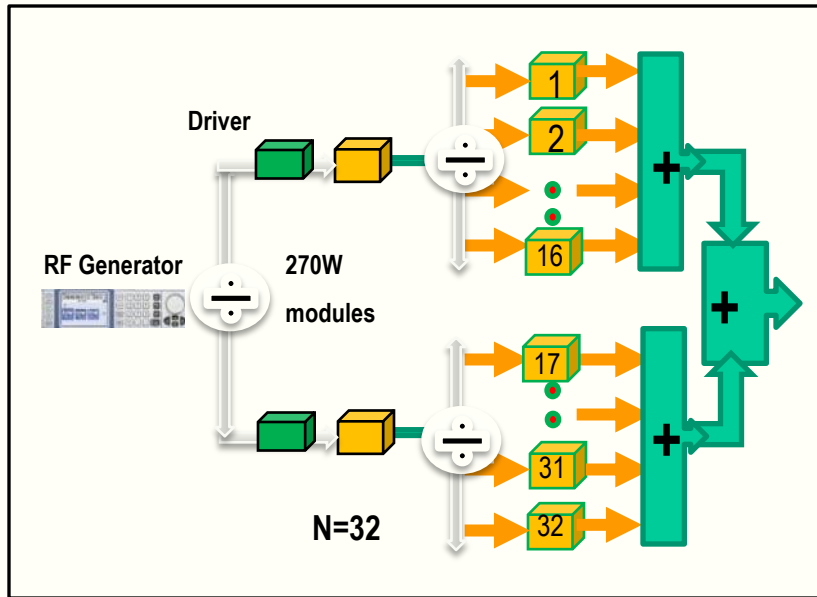

### 30kW Amplifier Scheme

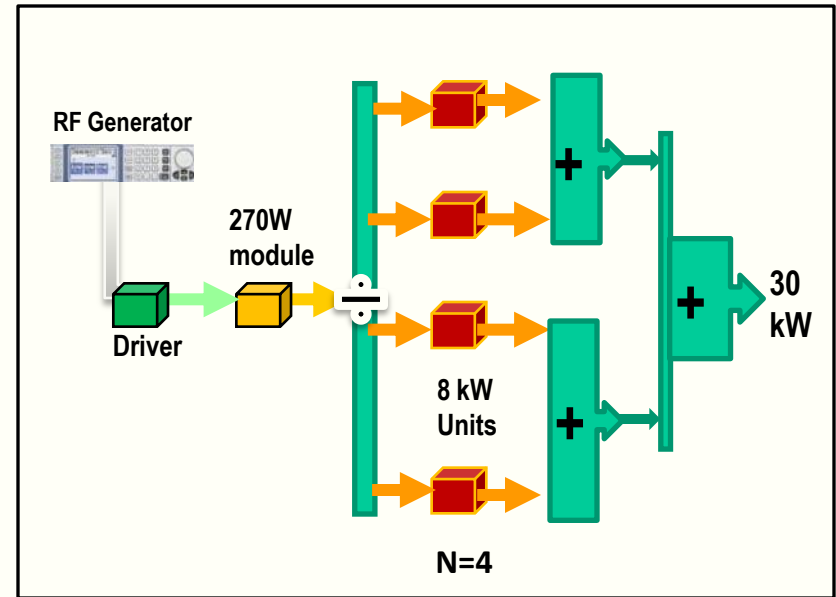

- 32 Nos. of 270 W RF modules are used with suitable combiners and dividers to make a 8 kW RF amplifier module. Four such modules will be combined to obtain 30 kW RF power output.

# Input coupler

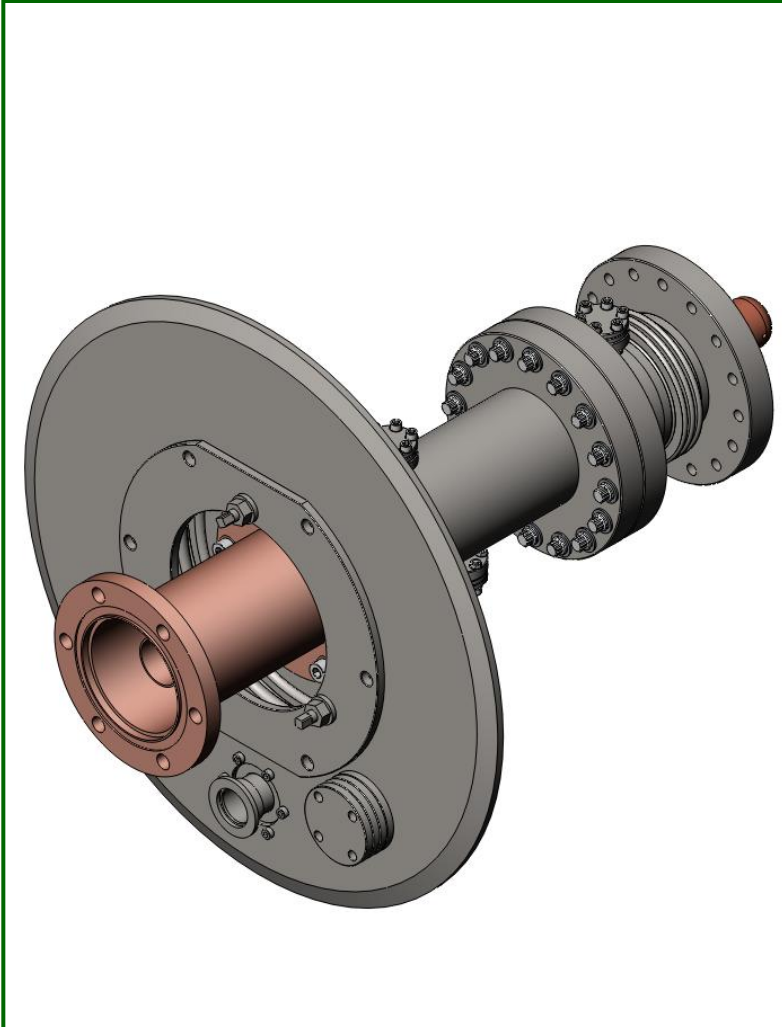

Coaxial design, adjustable, 76.9 mm outer/33.4 mm inner, two disk-type ceramic windows.

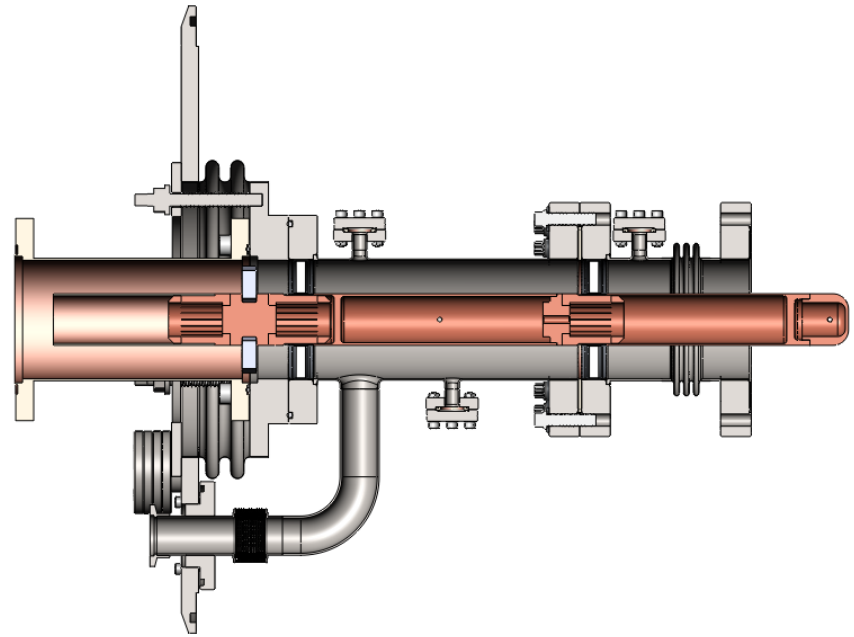

3 couplers are in-house and tested. One currently installed in test cryostat. Design modifications in-process to reduce weight.



# Phase III: Project-X

- **Fermilab and DAE accelerator laboratories have proposed to jointly work**
  - On the construction and commissioning of the Project-X accelerator at Fermilab
  - Development of Indian capabilities and industrial infrastructure that could lead the construction of HIPA in India.
- **India is expected to make significant In-Kind contributions**
  - US will share accelerator technology and knowledge
- **The Accelerator collaboration started in 2006 and has now gone into the 3rd stage**
  1. **Component level → Scientists to Scientists**
  2. **System Level → Laboratories to Laboratories**
  3. **Facility Level → Agency to Agency**
    - i. **Fermilab has worked with US DOE in developing a DOE-DAE agreement based on IIFC discussion to date)**
    - ii. **At present the US-DOE and DAE are working to negotiate the language and high level details of DOE-DAE agreement.**



Fermilab

# Collaboration on High Energy Physics



- Indian institutions have been collaborating on Fermilab based High Energy Physics experiments since 1986.
  - Several students have received PhD from Indian universities while working on Fermilab experiments.
- Recently we have established a Neutrino Physics collaboration with India
  - Indian Institutions have joined MINOS, MIPP and LBNE
  - Students and faculties are contributing to the analysis
    - Several PhD thesis
  - Faculty and engineering staff are getting involved in design of future experiments.
- We held a joint workshop in Jan 2011 to discuss collaboration on all aspect of High Energy Physics, Nuclear Physics and Energy
  - Support is overwhelming
  - We are developing a set of proposal for XII plan.





Fermilab

# Colleagues at Fermilab under IIFC



Accelerator: 5+1 (1 Student), HEP: 6+2 (5+2 Students)

IIFC Developing Indian Technical Expertise



# Summary



- Indian Institutions and Fermilab have established an excellent working relationship and are collaborating on SRF part of the High Power Linac for HIPA.
  - Progress is being made on several fronts.
- We are proceeding to expand this R&D collaboration to all non-SRF aspect of the accelerator.
- Fermilab has proposed to build a 3 GeV CW, ~3 MW SRF linac (followed by 3-8 GeV Pulsed SRF Linac) for its High Energy Physics program.
  - The design of this SRF linac is aligned with Indian 3<sup>rd</sup> Stage Nuclear program.
- This is an unprecedented opportunity for both Indian and US Institutions, and agencies to collaborate on jointly developing accelerators for its domestic program.
  - Total Project Collaboration
- During this meeting
  - we need to make significant technical progress on Phase I and II
  - Discuss steps that could be taken to make a plan for Phase III